



# 系統

2022基礎實驗技術訓練

雷射光電支援中心  
陳蔚然





# 系統（設備）

- 儀器操作與手冊研讀
- 真空系統
  - 真空概論：真空定義與分類、平均自由徑、管線、氣流
  - 真空器械：腔體、材料及真空相容性、幫浦、測漏、氣壓測量、殘氣分析、真空引入
- 雷射系統
  - 雷射基礎
  - 雷射應用
- 光學系統
  - 光譜儀、干涉儀、顯微鏡
- 溫控系統
- 系統模擬
  - 軟體簡介：Comsol.....





# 儀器操作

- 研讀使用手冊
- 了解儀器功能
- 了解實驗儀器操作程序 (SOP)
- 日常保養
- 故障排除





# 研讀操作手冊

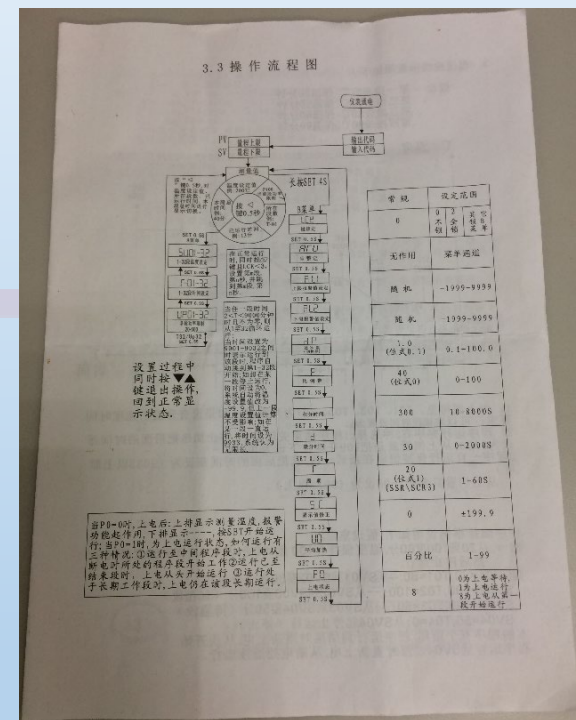



# 真空技術

- 真空概論：真空定義與分類、平均自由徑、管線、氣流。
- 真空器械：腔體、材料、幫浦、測漏、真空測量、殘氣分析、真空引入。
- 真空系統





# 壓力單位

- $1 \text{ atm} = 1,013,250 \text{ dyne/cm}^2 = 14.7 \text{ lb/in}^2(\text{psi})$
- $1 \text{ atm} = 760 \text{ mm Hg} = 760 \text{ Torr} = 1013 \text{ mbar}$
- $1 \text{ bar} = 10^6 \text{ dyne/cm}^2 = 0.98692 \text{ atm} = 10^5 \text{ Pa}$
- $1 \text{ Pa} = 1 \text{ N/mm}^2 \text{ (ISO, SI unit)} = 133 \text{ Torr}$





# 壓力範圍

- 低度真空 Low (rough) Vacuum:
  - Atmosphere down to 1 Torr
  - Non-industrial applications
- 中度真空 Medium Vacuum:
  - 1 Torr to  $1 \times 10^{-3}$  Torr
  - CVD, evaporators
- 高度真空 High Vacuum:
  - $1 \times 10^{-3}$  to  $1 \times 10^{-7}$  Torr
  - Ion implanters, sputterers
- 超高真空 Ultra-high Vacuum:
  - Less than  $1 \times 10^{-7}$  Torr
  - Molecular beam epitaxy
  - Research instruments





# 氣體動力論

- 氣體定律 Gas Laws and Models
- 平均自由徑 Mean Free Path
- 氣導 Conductance





# 氣體定律

- 理想氣體定律：
  - $PV = nRT$
- Maxwell-Boltzmann distribution
  - $V_{mp} = (2kT/m)^{-2}$  (most probable velocity)
  - $V_{rms} = (3kT/m)^{-2}$  (average velocity)





# 平均自由徑(MFP)

粒子在再次碰撞之間所飛行的平均距離

$$\lambda \cong \frac{5 \times 10^{-3}}{P(\text{torr})} \text{ cm}$$

for molecules of  
3 Å diameter  
and  $\bar{v} \cong 500 \text{ m/s}$

$$P = 760 \text{ torr} \quad \lambda = 700 \text{ \AA} \quad \tau = 0.14 \text{ ns}$$

$$P = 1 \text{ torr} \quad \lambda = 50 \text{ \mu m} \quad \tau = 100 \text{ ns}$$

$$P = 10^{-3} \text{ torr} \quad \lambda = 5 \text{ cm} \quad \tau = 100 \text{ \mu s}$$

$$P = 10^{-6} \text{ torr} \quad \lambda = 50 \text{ m} \quad \tau = 0.1 \text{ s}$$





# 氣流

- 黏滯流
  - 平均自由徑  $<$  腔體尺寸
- 過渡流
- 分子流
  - 平均自由徑  $>$  腔體尺寸





# 氣導 (Conductance)

For a typical pump, the amount of gas pumping out is proportional to  $P$ , so pumping speed  $S$  is defined as

$$\frac{\delta PV}{\delta t} = PS \quad S = \frac{1}{P} \frac{\delta PV}{\delta t}$$

$S$  in liters per second,  $\ell/s$

Throughput

$$Q = PS \quad \text{in torr } \ell/s$$

Usually, throughput is conserved. (Steady state)

$$Q = P_1 S_1 = P_2 S_2$$

$$P_2 = 100 P_1$$

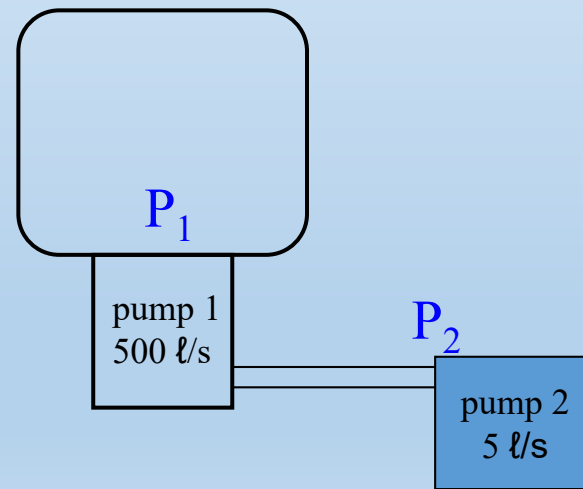



# 氣導 (Conductance)

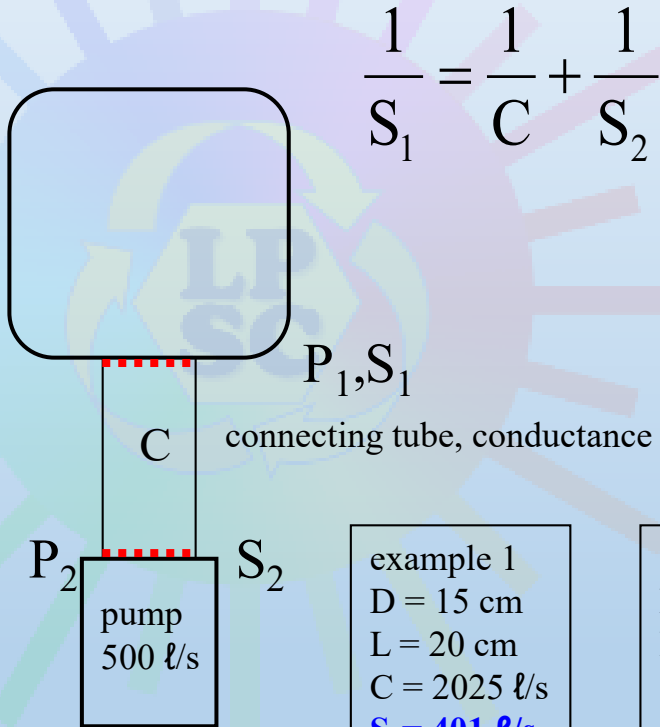

$$\frac{1}{S_1} = \frac{1}{C} + \frac{1}{S_2}$$

$D$  = diameter, in cm  
 $L$  = length, in cm  
 $C$  = conductance, in  $\ell/s$

$$C = 12 \frac{D^3}{L} \quad @ \text{ molecular flow}$$

example 1  
 $D = 15 \text{ cm}$   
 $L = 20 \text{ cm}$   
 $C = 2025 \ell/s$   
 $S_1 = 401 \ell/s$

example 2  
 $D = 10 \text{ cm}$   
 $L = 20 \text{ cm}$   
 $C = 600 \ell/s$   
 $S_1 = 273 \ell/s$





$$C = 12 \frac{D^3}{L} \quad @ \text{ molecular flow, } D \sim 5 \text{ cm, } P < \text{ mtorr}$$

$$C = 180 \frac{D^4}{L} P_{\text{av}} \quad @ \text{ viscous flow, } P > \text{ mtorr}$$

$$\lambda = 5 \text{ cm @ } 1 \text{ mtorr}$$

D = diameter, in **cm**  
L = length, in **cm**  
C = conductance, in **ℓ/s**  
P<sub>av</sub> = average pressure, in **torr**

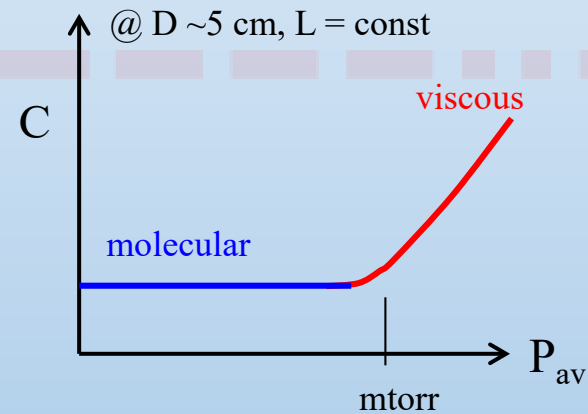



# 真空泵浦

- 操作方式
  - 排氣式
  - 儲氣式
- 泵浦特性
  - 終極壓力
  - 泵浦速率  $l/s$ ,  $m^3/hr$
  - 工作壓力範圍





# 迴轉油封泵浦

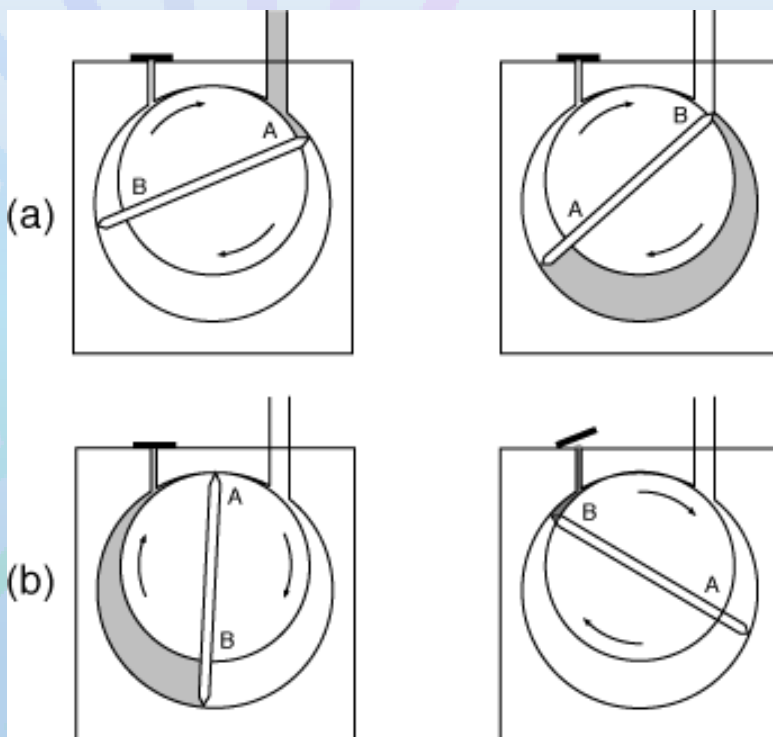

single stage: down to  $10^{-1}$  torr

two stage: down to  $10^{-3}$  torr

Pumping speed: 2 – 1000  $\text{m}^3/\text{hr}$





# 渦卷式泵浦(Scroll pmup)

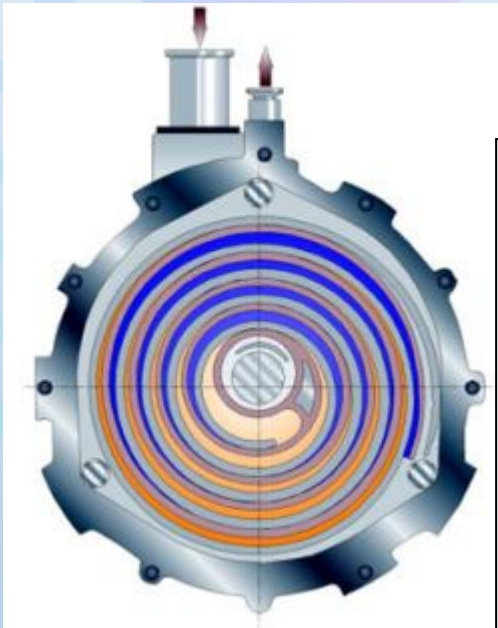

泵浦速率：20 – 40 m<sup>3</sup>/hr  
終極壓力：~ 10<sup>2</sup> Torr

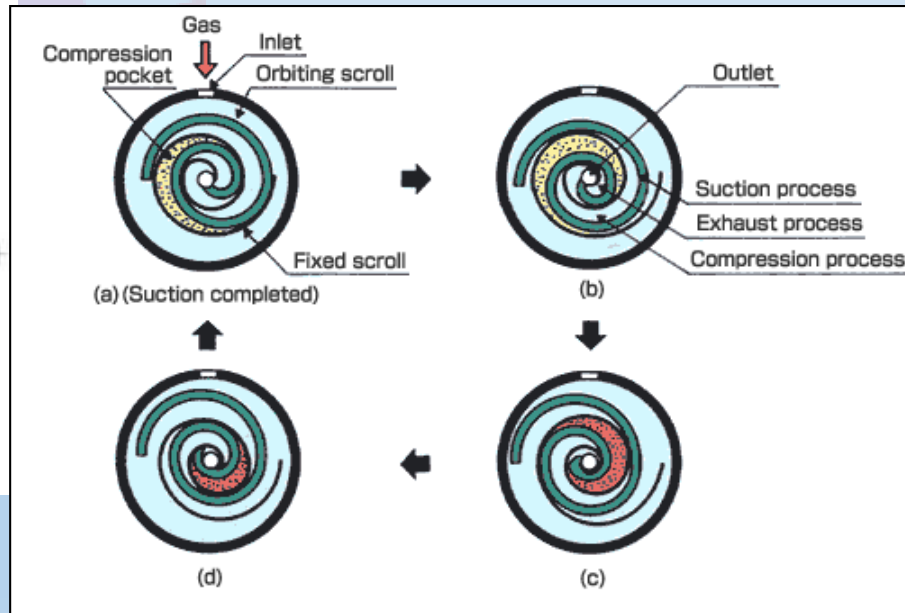



# 魯式泵浦(Roots pump)

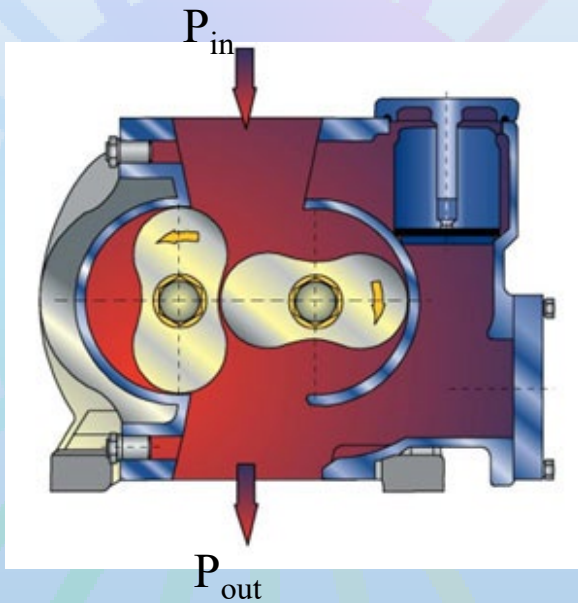

to rotary pump

終極壓力： $\sim 10^{-4}$  Torr

抽氣速率： $\sim 1800$  m<sup>3</sup>/hr





# 擴散泵浦

操作壓力： $10^{-3} - 10^{-7}$  Torr

Highest pumping speeds for the  
Lightest gases: 12 – 50000 l/s

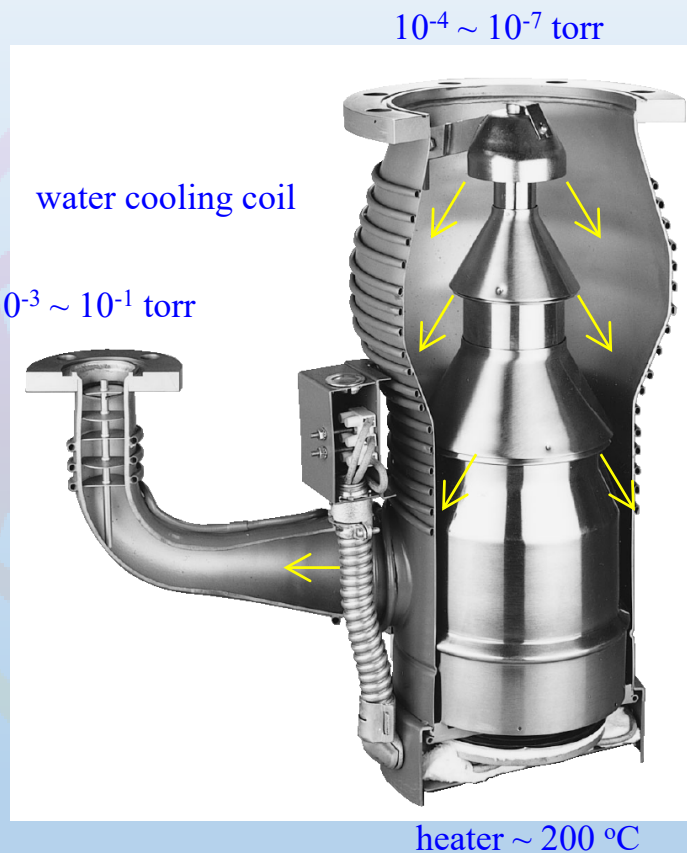

# 冷凍泵浦(Cryopump)

Cryopump

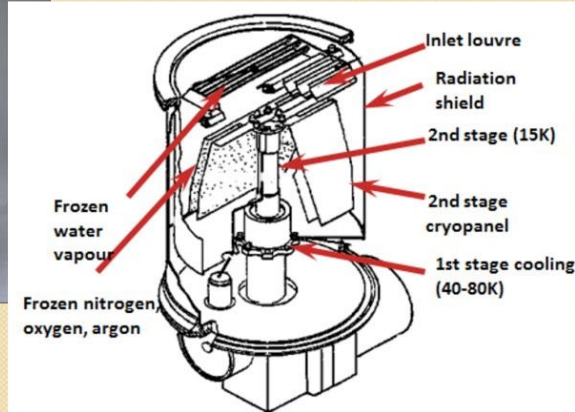

終極壓力： $\sim 10^{-10}$  Torr

抽氣速率：800 – 60000 l/s





# 渦輪分子泵浦

There are stators to block bouncing back  
(not shown)

終極壓力： $10^{-7}$ — $10^{-10}$  Torr  
泵浦速率：50—3500 l/s

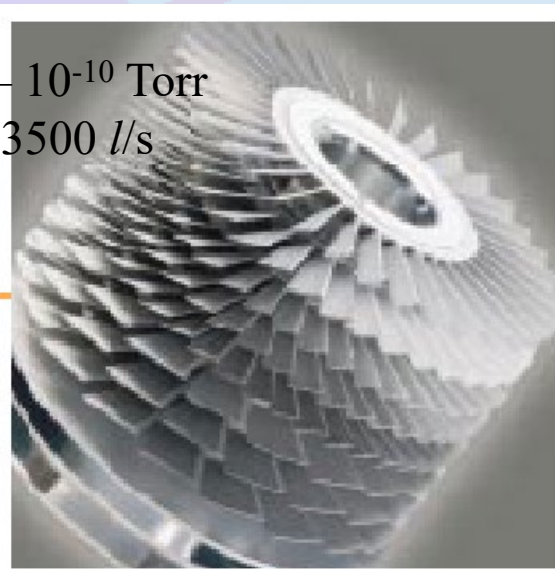

# 離子泵浦

終極壓力： $< 10^{-11}$  Torr  
抽氣速率：4 - 500  $l/s$

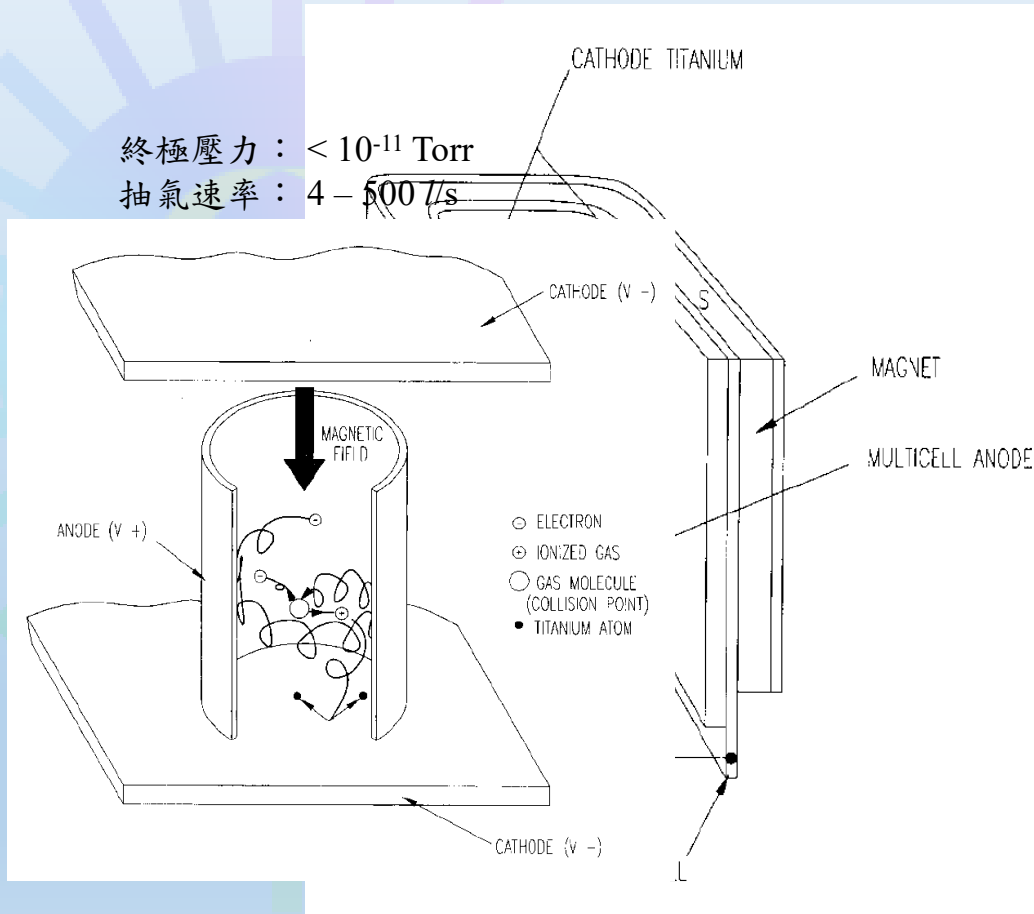



# 真空測量

- 利用各種物理原理來量測壓力或氣體分子數目的多寡
- 直接測量
  - 測量方法是依據壓力之定義，即單位面積上所受之力來測量
- 間接測量
  - 測量方法為利用氣體物理特性（如熱傳導、游離性、黏滯性）間接測量而得的



# 包登管式 (Bourdon) 真空計

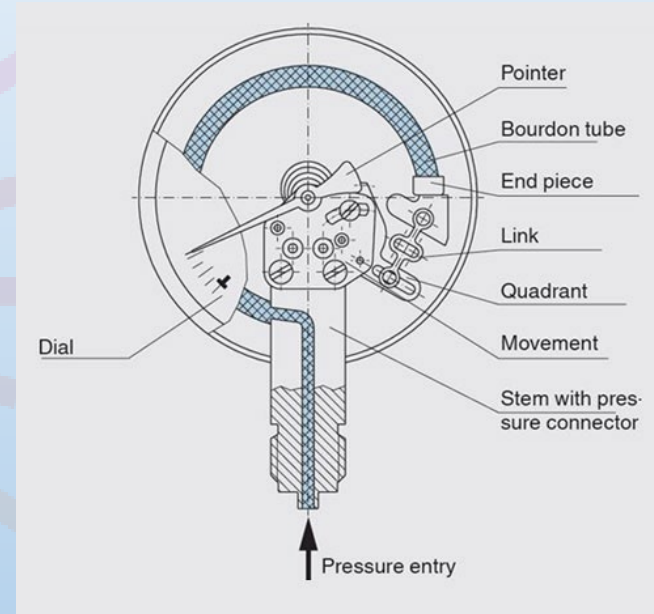

量測範圍：1 Torr 至 760 Torr





# 隔膜式真空計

- 量測壓力範圍：1 Torr 至 1500 Torr
- 藉著金屬薄膜因壓力差而產生形變，再利用機械、電壓或是光學方式，將此變化量放大顯示出來



# 電容薄膜式真空計

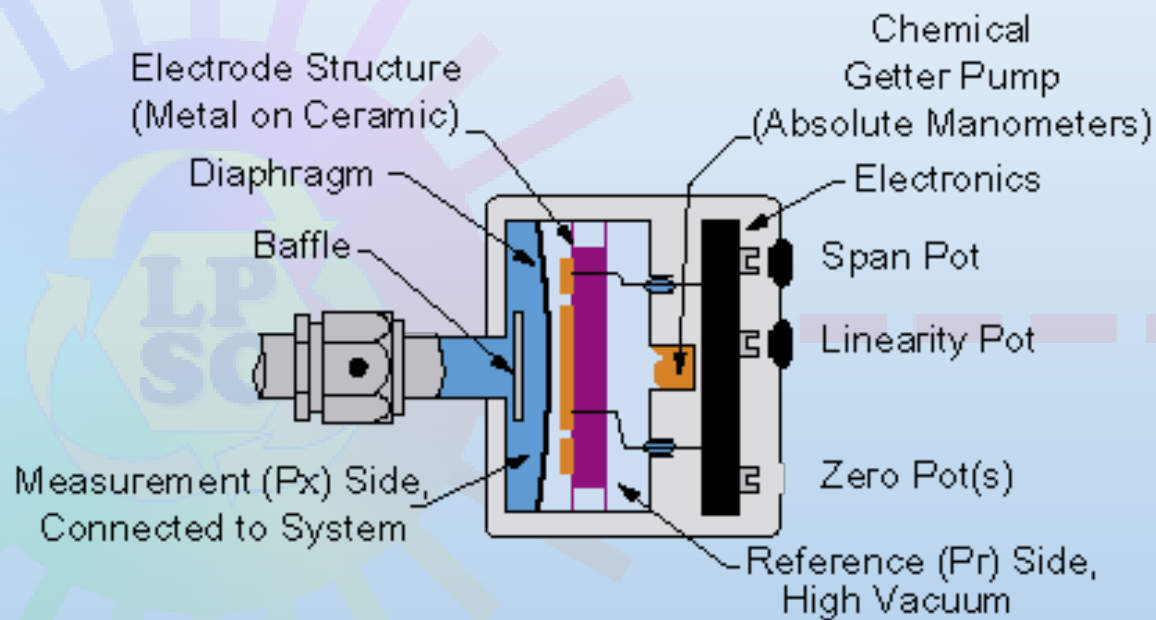

測量範圍： $10^{-5}$  Torr 至 1000 Torr





# 熱傳導真空計

- 熱電偶真空計
- 派藍尼真空計
- 熱對流真空計



# 熱電偶真空計

一個加熱燈絲在真空中的散熱方式有三種：

- (1) 由燈絲接頭處直接傳導
- (2) 由燈絲直接將熱能輻射到周圍環境
- (3) 由燈絲附近的氣體分子撞擊燈絲而帶走熱量。此種靠氣體分子碰撞而導熱的作用在某一段壓力範圍內會隨壓力變化而變化，超過此段壓力範圍則失去其作用，通常此壓力範圍約在1 Torr到 $10^{-4}$  Torr之間。

熱電偶溫度計：

當加熱燈絲因真空壓力變化而溫度改變時，連於其上的熱電偶就產生輸出電壓的改變。一般所用的加熱燈絲為鎢絲或鉑薄片。

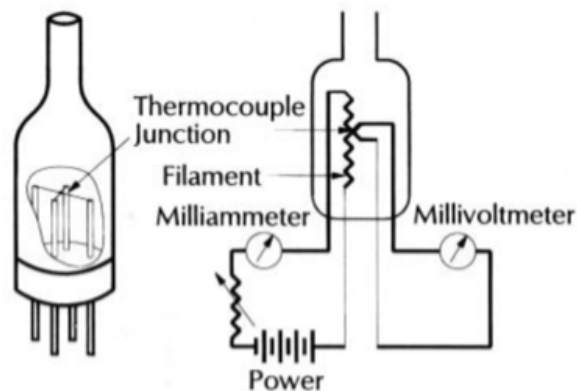

# 派藍尼(Pirani)真空計

在Pirani gauge中，兩個加熱燈絲分別被用做惠斯同電橋中的兩個電阻，一個參考燈絲曝露在一已知的固定氣壓中，另一個燈絲則曝露在戴測的系統中。

Pirani gauge的操作方式有二

- (1) 當氣壓變化時，調整燈絲上所加的電壓以維持其溫度不變。由改變的燈絲電壓即可決定真空的壓力。
- (2) 由燈絲的電阻值變化而測定真空的壓力，由測定電阻值就可測得真空壓力。

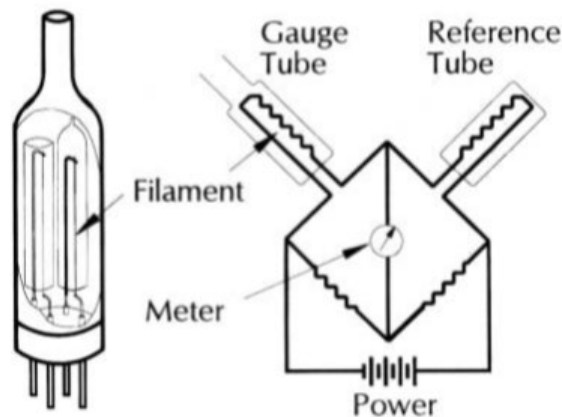

因為各種氣體的比熱及其撞擊燈絲時所能帶走的熱不盡相同，故此種真空計必須對不同氣體做校正，否則測得的壓力誤差甚大。





# 熱對流真空計

Convectron gauge

**GRANVILLE-PHILLIPS**  
HELIX TECHNOLOGY CORPORATION

CONVECTRON®  
Vacuum Measurement System  
Series 275



**Operating pressure** : atmosphere to  $10^{-4}$  Torr

**Sensor material** : gold-plated tungsten

In general, convectron gauge tubes are used to gain a indication of the vacuum in a system rather than an accurate measurement.

與派藍尼真空計類似，僅在感測頭加裝了溫度補償線圈及使用鍍金之鎢絲線，其操作原理包括熱傳導及熱對流，因此使得量測範圍更寬廣。





# 離子真空計

- 熱陰極離子真空計
- 冷陰極離子真空計



LP  
SC





# 熱陰極離子真空計

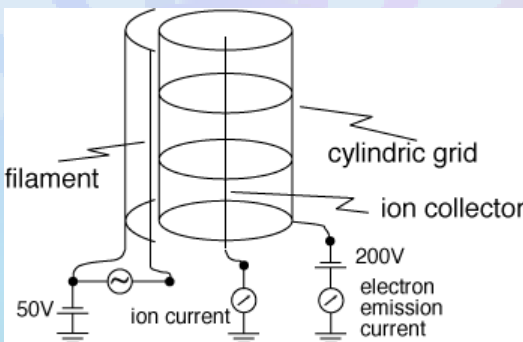

$10^{-11} \sim 10^{-3}$  torr  
 linear sensitivity  
 absolute zero point  
 species dependent



sensitivity  $\propto$  ionization cross section

air, N<sub>2</sub>, O<sub>2</sub> 1.0

He 0.15

Ne 0.3

H<sub>2</sub> 0.4

CH<sub>4</sub> 1.4





# 冷陰極離子真空計

similar to hot cathode ion gauge

more robust

less accurate

hard to ignite at low pressure

magnet

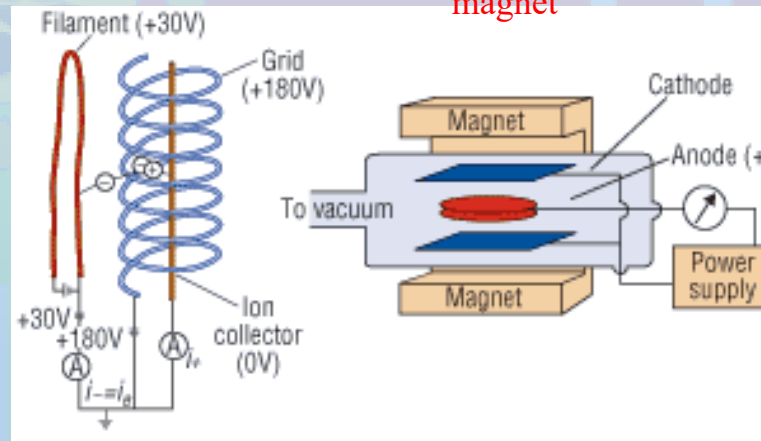

Hot

Cold





# 殘餘氣體分析儀(RGA)

A small quadrupole mass analyzer with an electron impact ionizer

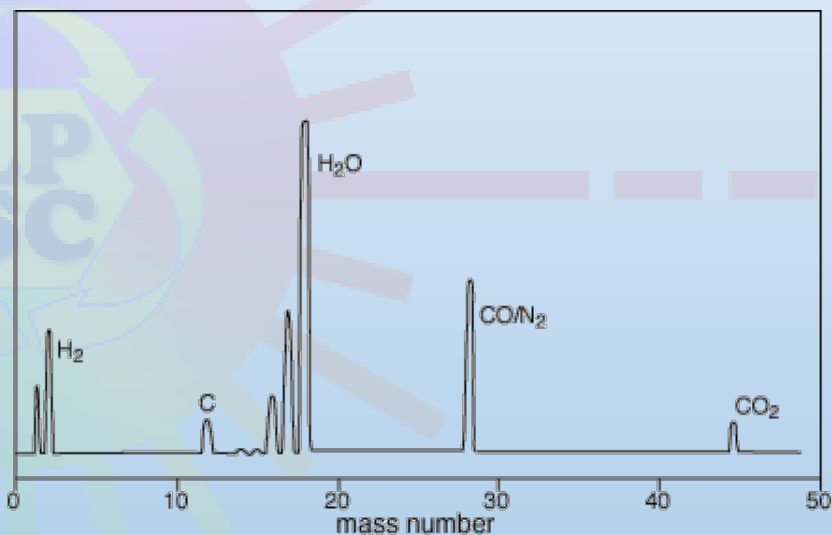

With electron multiplier, sensitivity  $\sim 10^{-15}$  torr





# 真空系統

- 真空腔體
  - 材料
  - 腔體連結
- 系統組件
  - 閥門
  - 真空引入
- 系統測漏





# 影響真空的因素

(1) Outgassing(逸氣)

(2) Sublimation and evaporation (昇華與蒸發)

- \* 飽和蒸氣壓
- \* 昇華與蒸發速率

(3) Diffusion and permeability  
(擴散與滲透)

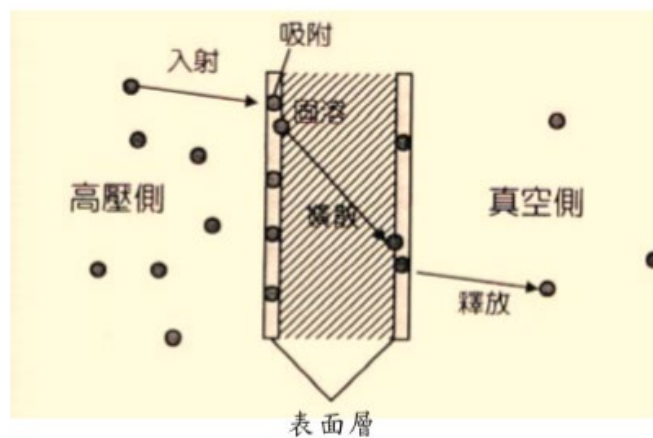



# 選擇材料

- (1) 材料組織必須均勻質密，無微細孔隙以免氣體滲透入內。
- (2) 必須有夠低的蒸氣壓。
- (3) 不含雜質或氣體，不易吸附氣體也不易逸氣。
- (4) 可耐高溫烘烤或低溫冷凍。

常用的真空結構材料:

- (1) 金屬：若非用於超高真空系統，通常金屬的蒸發量微乎其微,可視為不蒸發。
- (2) 玻璃：最早的真空儀器多是用玻璃製成，玻璃透明且加工容易。  
**缺點**是材料強度小，易破裂，不耐高溫。

其他常用於真空內的非金屬材料：

陶瓷(ceramic)，人造橡皮，鐵弗龍(teflon)，Fused Silica，sapphire.....



# 法蘭

Flange通指圓盤狀有凸出邊緣的元件，在真空系統用作可拆接頭。Flange相互連接時必須要有seal(或gasket)卡於其間以達到真空緊密的要求。一般所用的seal可分，為彈性體(elastomer)與金屬兩大類，flange的設計隨seal的不同亦有不同的構造。

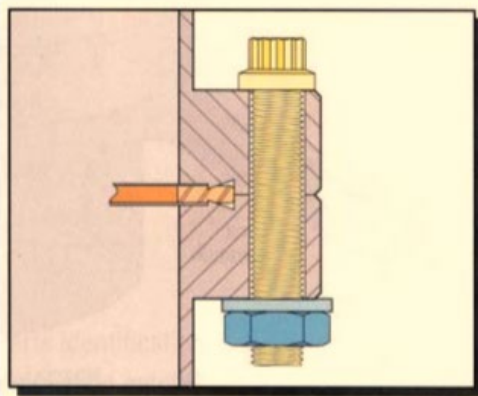

Del-Seal™ CF metal gasket geometry

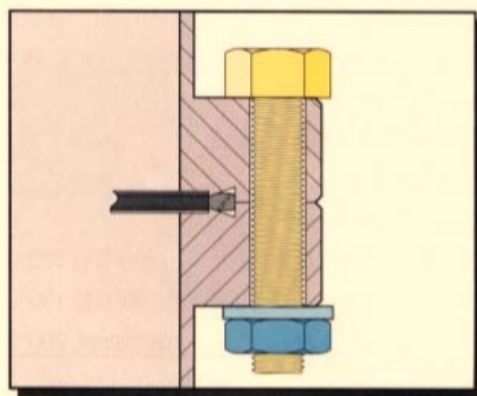

Del-Seal™ CF elastomer gasket geometry





# CF flange

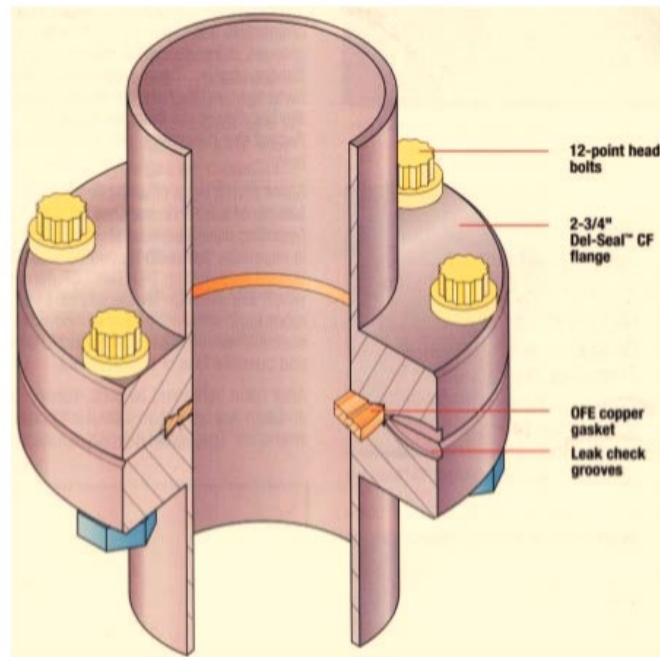



# QF flange

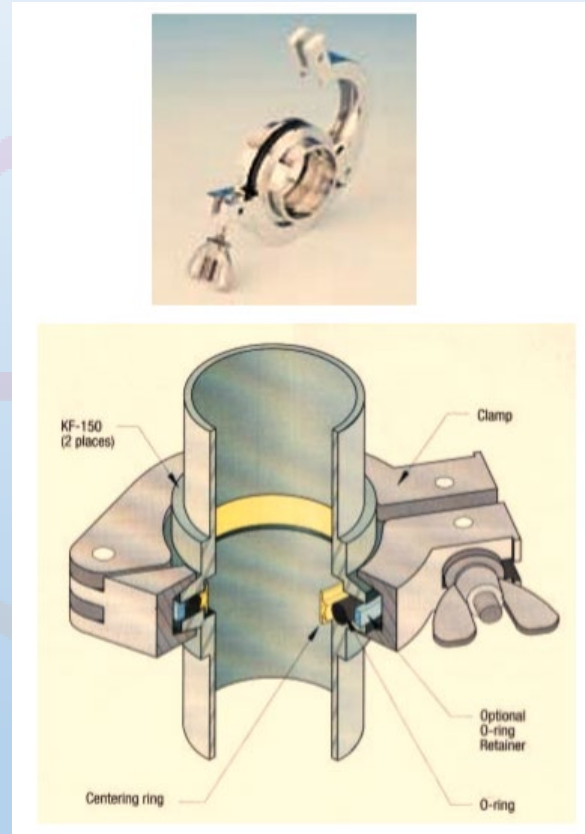
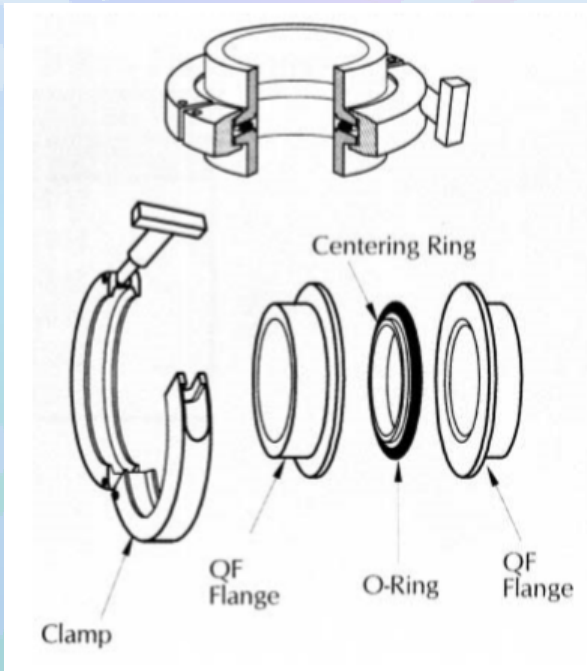



# Elbows and Tees





# Nipples and belows



CF



QF





# Multi-way crosses





# Reducers and adaptors



QF reducer

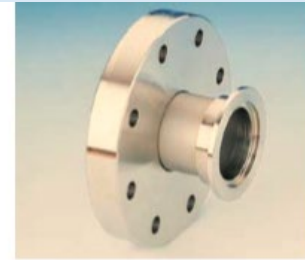

CF to QF adaptor



straight tube reducer(CF)



zero-length reducer (CF)



ASA to CF adaptor





# Viewports and windows

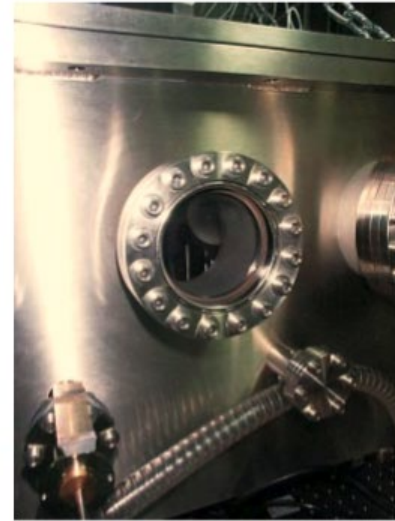



# Gate valve

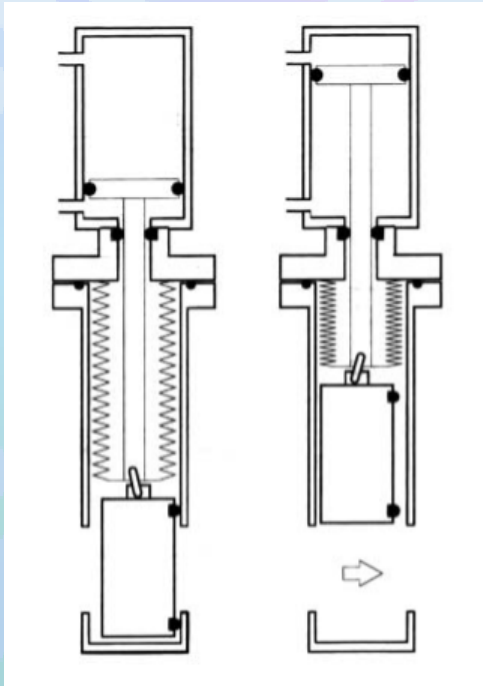



# Angle valve

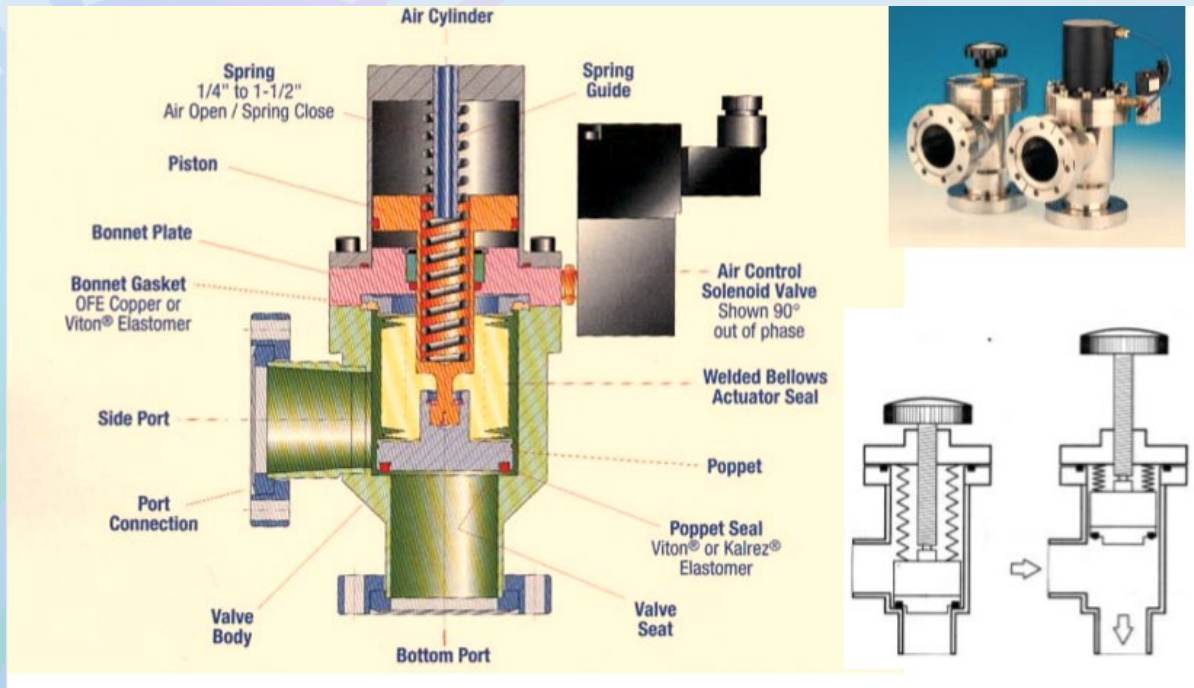



# Inline valve

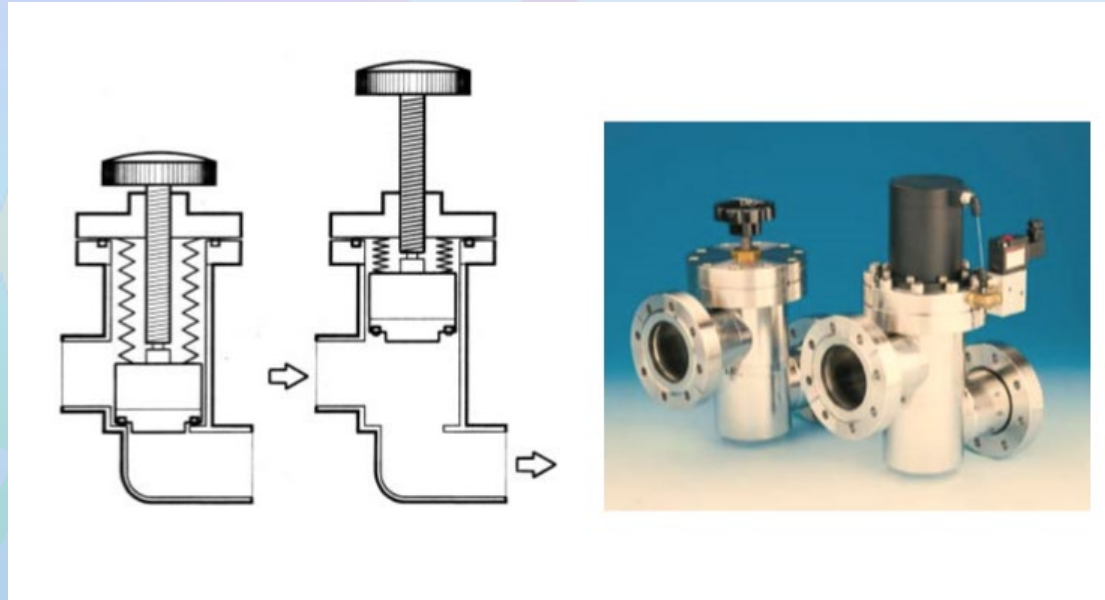



# Butterfly valve

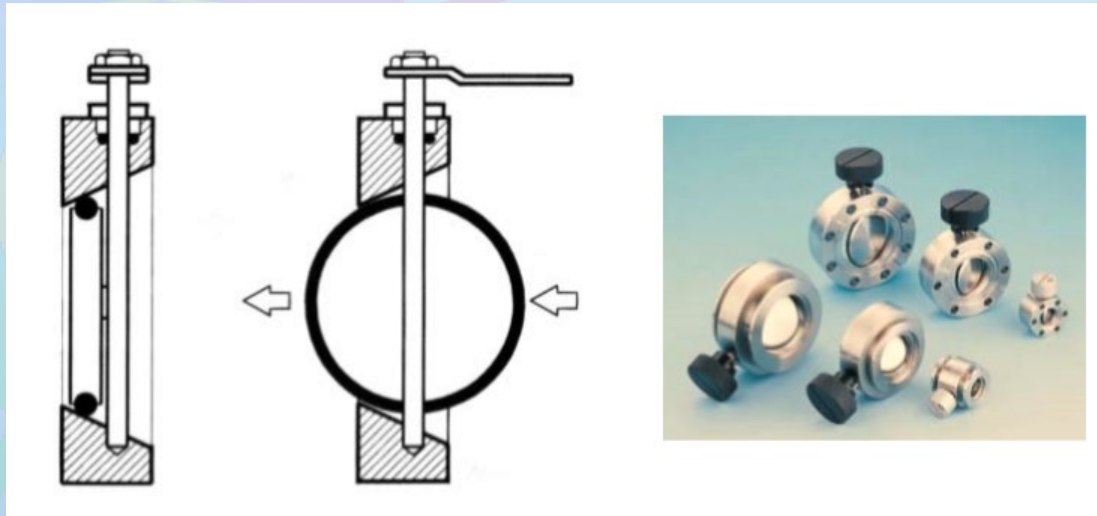



# Electrical feedthrough

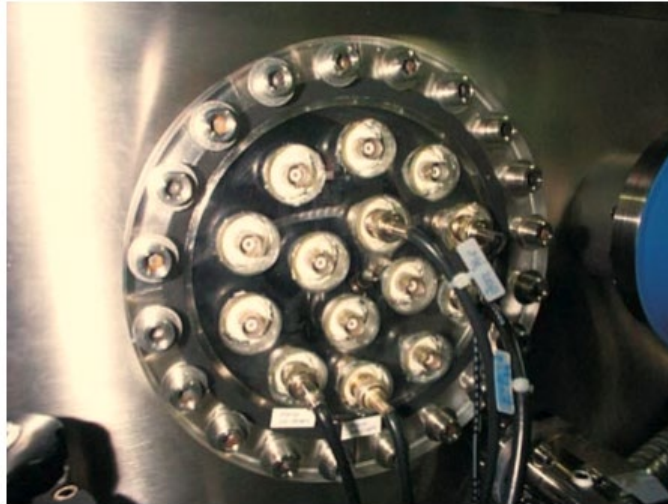

BNC feedthrough





# Motion feedthrough



rotation + translation feedthrough



precision rotation + translation  
feedthrough





# Homework

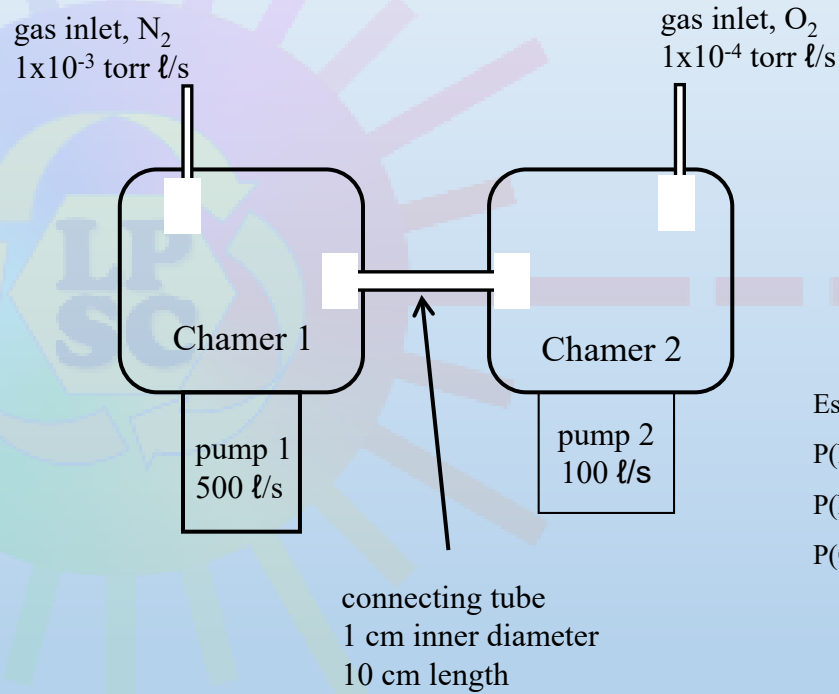

Estimate:

$P(N_2)$  in chamber 1

$P(N_2)$  in chamber 2

$P(O_2)$  in chamber 1





# 雷射光學系統

- 基礎雷射原理與發展
- 各式雷射
- 非同調光源
- 光譜儀光學





# 受激輻射

- 1917: Albert Einstein performs fundamental studies on the nature of light, discovering the principles of spontaneous and **stimulated emission**.

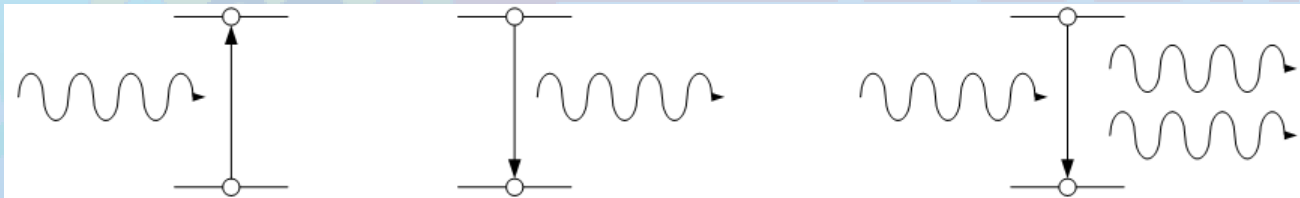

受激吸收

自發輻  
射

受激輻射

- 1928: Rudolph W. Landenburg confirms existence of stimulated emission.





# 粒子數反轉

- 1940: V.A Fabrikant suggests method for producing population inversion in his PhD thesis.
- 1951: In an experiment using nuclear magnetic resonance, Edward Purcell and Robert Pound introduce the concept of negative temperature, to describe the inverted populations of states usually necessary for maser and laser action.

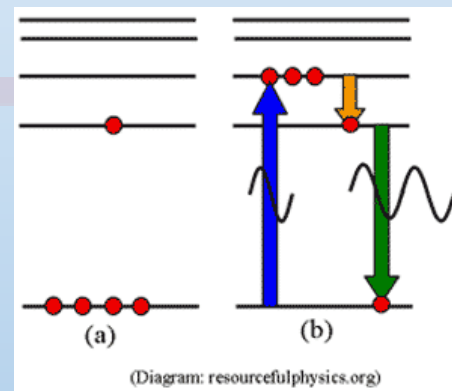



# 雷射產生三個基本要素

- 「**激發來源**」（**pumping source**）：又稱「**泵浦源**」，把能量供給低能階的電子，激發使其成為高能階電子，能量供給的方式有電荷放電、光子、化學作用等。
- 「**增益介質**」（**gain medium**）：被激發、釋放光子的電子所在的物質，其物理特性會影響所產生雷射的波長等特性。
- 「**共振腔**」（**optical cavity/optical resonator**）：是兩面互相平行的鏡子，一面全反射，一面半反射。作用是把光線在反射鏡間來回反射，目的是使被激發的光多次經過增益介質以得到足夠的放大，當放大到可以穿透半反射鏡時，雷射便從半反射鏡發射出去。因此，此半反鏡也被稱為**輸出耦合鏡**（**output coupler**）。兩鏡面之間的距離也對輸出的雷射波長有著選擇作用，只有在兩鏡間的距離能產生共振的波長才能產生雷射。





# 1960

- May 16, 1960: Theodore Maiman, C.K. Asawa, and I.J. D'Haenens develop **first working laser** at Hughes Research Labs. Immediately reproduced by numerous laboratories.





# 1960

- 1960: Ali Javan, William Bennett, and Donald Herriott at Bell Labs develop first **helium neon (HeNe) gas laser**.

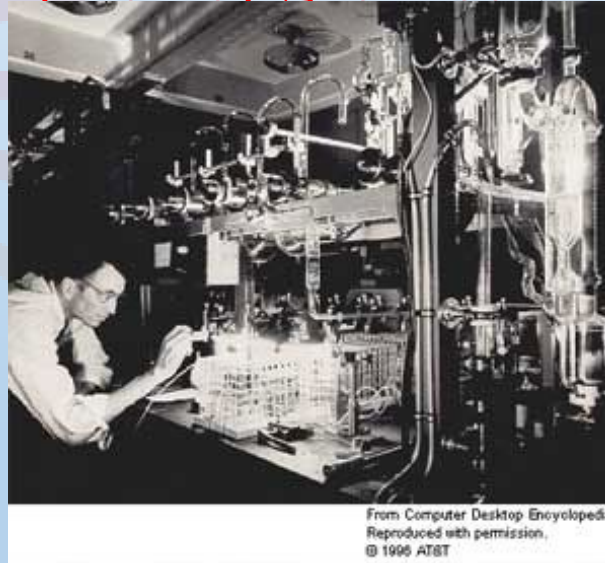

From Computer Desktop Encyclopedia  
Reproduced with permission,  
© 1996 AT&T





# 1962



- 1962: Four groups in the US (M. I. Nathan et al., R. N. Hall et al, T. M. Quist et al, N. Holonyak and S. F. Bevacqua) nearly simultaneously make first **semiconductor diode lasers**, which operate pulsed at liquid-nitrogen temperature. Important step in the development of optical communication, optical storage, optical pumping of solid-state lasers and many other applications.





# 1962

- 1962: F. J. McClung and R. W. Hellwarth develop laser **Q-switching**, which gives lasers short pulses and high peak powers.

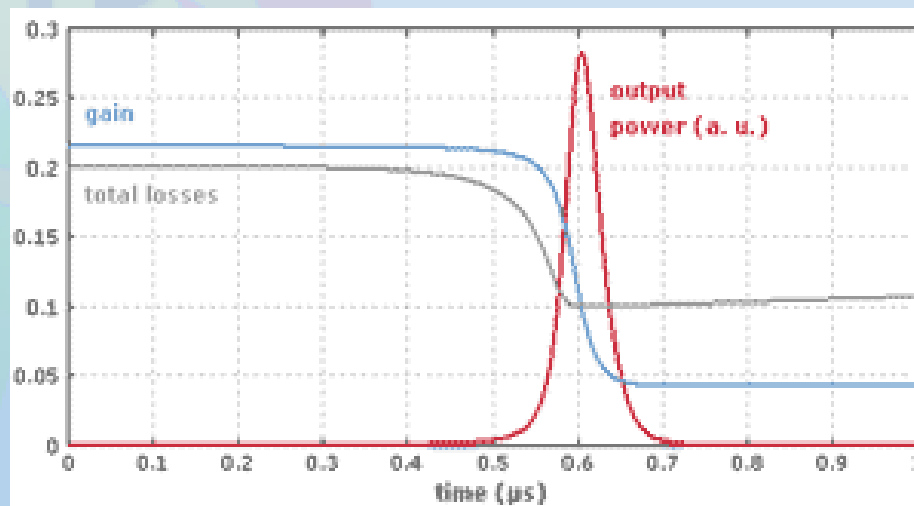



# 1963

- 1963: L. E. Hargrove, R. L. Fork, and M. A. Pollack report the first demonstration of a **mode locked laser**, i.e. a helium-neon laser, with an acousto-optic modulator. Mode locking is the basis for the femtosecond pulsed laser.

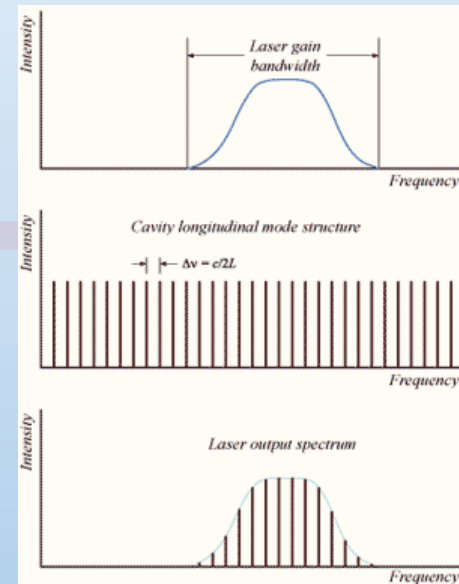



# 1966

- 1966: Peter Sorokin and John R. Lankard built the first widely **tunable organic dye laser**, now used in ultrafast science and spectroscopy.

Peter Sorokin with the flash lamp-pumped dye laser, in 1968. Photo courtesy of IBM

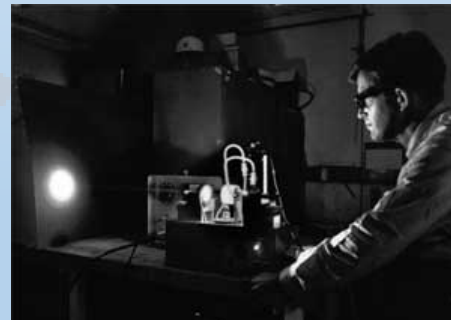



# Nobel Prize



- 1964: Charles H. Townes, Alexander M. Prokhorov, and Nicolay G. Basov are awarded the Nobel Prize in Physics "for fundamental work in the field of quantum electronics, which has led to the construction of oscillators and amplifiers based on the **maser-laser principle**."





# Nobel Prize



- 1971: Dennis Gabor is awarded the Nobel Prize in Physics for "his invention and development of the holographic method." While he outlined **holography** in a series of papers from 1946 to 1951, it was not until the invention of the laser that an effective hologram could be built.

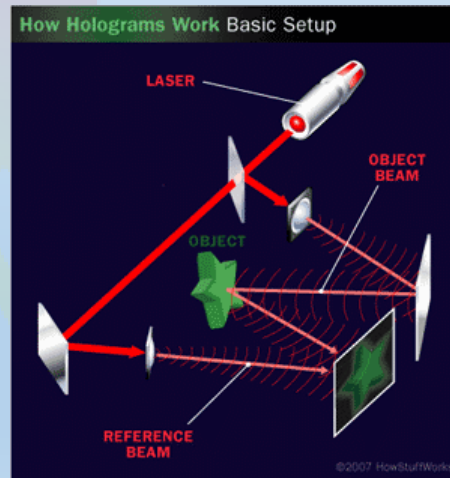



# Femtosecond Laser

- 1974: E. P. Ippen and C. V. Shank develop the sub-picosecond mode-locked CW **dye laser**, establishing ultrafast optical science.
- 1982: P. F. Moulton develops **titanium -sapphire laser**. The titanium -sapphire laser replaces the dye laser for tunable and ultrafast laser applications.

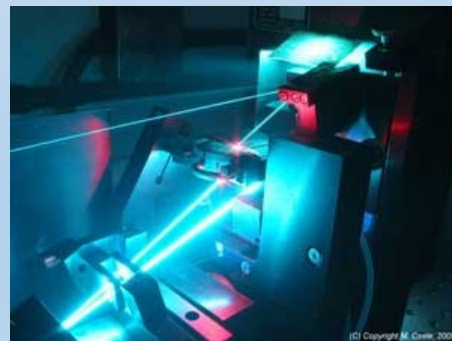



Laser pulses got shorter  
over the years

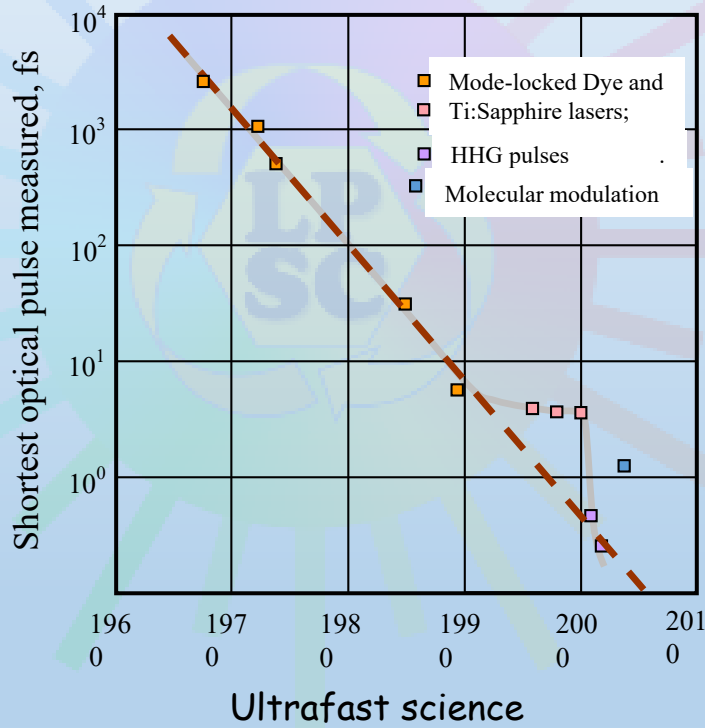

Peak intensity  
increased

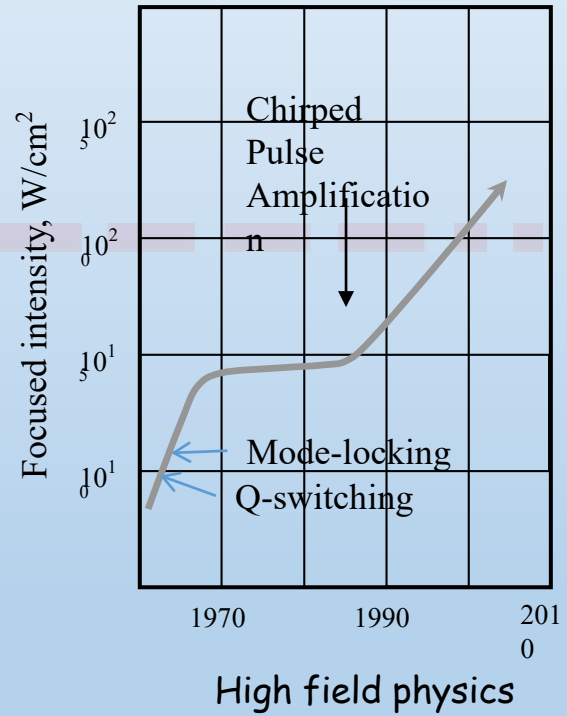



# Nobel Prize



- 1981: Arthur Schawlow and Nicolaas Bloembergen are awarded the Nobel Prize in Physics for their "contribution to the development of **laser spectroscopy**."
- 1985: Steven Chu, Claude Cohen-Tannoudji, and William D. Phillips develop methods to **cool and trap atoms with laser light**.. They are awarded the Nobel Prize in Physics in 1997.





# Nobel Prize



- **1999: Ahmed Zewail**  
Zewail successfully used a rapid laser technique called **femtosecond spectroscopy** to observe how atoms in a molecule move during a chemical reaction. In femtosecond spectroscopy, a pump-probe experiment "photographs" chemical reactions as they happen, using an ultrafast laser as "flash".





# Nobel Prize



- 2000: John Hall & Theodor Hansch develop **optical frequency comb** technique used in research as well as in precision metrology and time measurement. This work leads to their receiving the 2005 Nobel Prize in Physics.
- 2001: Eric Cornell, Carl Wieman, Wolfgang Ketterle are awarded the Nobel Prize in Physics for the “achievement of **Bose-Einstein condensation** in dilute gases of alkali atoms, and for the early fundamental studies of the properties of the condensates.”





# Nobel Prize



- 2005 光相干量子理論和雷射精密光譜學
- 2009 光纖與圖像傳感器的發明
- 2012 個別量子系統的測量和操縱
- 2014 發明藍光LED
- 2017 LIGO (Laser Interferometer Gravitational-Wave Observatory)
- 2018 CPA , Optical tweezers





# Extreme Lasers

**Longest laser:** **1.3 km (0.8 miles)**. This is the length of the Linac Coherent Light Source, a "free-electron" X-ray laser

**Shortest laser:** **Several millionths of a meter in length**. This is the length of the resonator in vertical-cavity surface-emitting lasers, or VCSELs.

(A **spaser** or **plasmonic laser** is a type of [laser](#) which aims to confine light at a [subwavelength](#) scale far below [Rayleigh's diffraction limit of light](#))

**Highest-energy laser pulse:** **150 thousand joules, in a single 10-nsec pulse**. The National Ignition Facility (NIF) at the Lawrence Livermore National Laboratory in Livermore, California, achieved this result in 2005.

**Highest instantaneous power:** University of Michigan focuses 30 fs pulses from Hercules Ti:Sapphire laser to a record intensity of  $2 \times 10^{22} \text{ W/cm}^2$ .

**Shortest laser pulse:** Illuminating neon gas with an ultrafast laser pulse generates **80 attosecond** pulses at Max Planck Institute for Quantum Optics, and is less than the time for a single oscillation cycle of a visible light wave. In order to make such a short pulse, researchers have to **generate light containing all colors from the visible region well into the ultraviolet region of the spectrum**. Such a pulse of light looks white to the eye. This is very different from typical lasers, which emit a single color.





# 雷射光調制

光與物質的交互作用

## 1. anisotropy

$$\begin{aligned} \mathbf{D} &= \epsilon_0 \mathbf{E} + \mathbf{P} \\ &= \epsilon_0 \mathbf{E} + \epsilon_0 \overset{\leftrightarrow}{\chi} \cdot \mathbf{E} \\ &= \overset{\leftrightarrow}{\epsilon} \cdot \mathbf{E} \end{aligned}$$

$$\overset{\leftrightarrow}{\epsilon} = \begin{bmatrix} \epsilon_x & 0 & 0 \\ 0 & \epsilon_y & 0 \\ 0 & 0 & \epsilon_z \end{bmatrix}$$

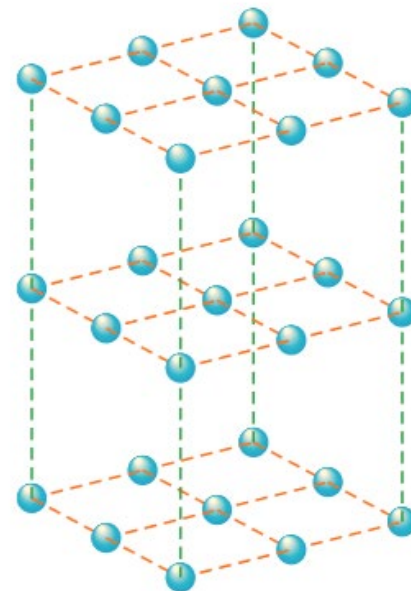
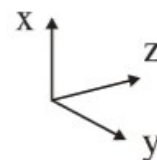

## 2. birefringence



$$\mathbf{E} = E \hat{x}$$

$$\mathbf{D} = \epsilon_x E \hat{x}$$

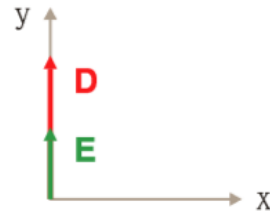

$$\mathbf{E} = E \hat{y}$$

$$\mathbf{D} = \epsilon_y E \hat{y}$$

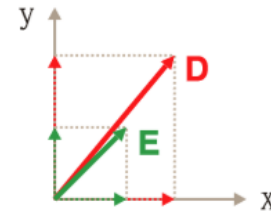

$$\mathbf{E} = E \hat{x} + E \hat{y}$$

$$\mathbf{D} = \epsilon_x E \hat{x} + \epsilon_y E \hat{y}$$

ordinary wave

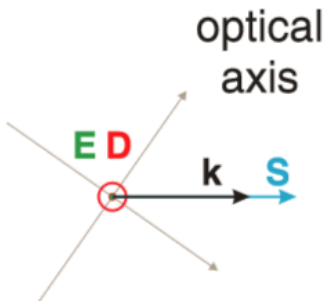

extraordinary wave

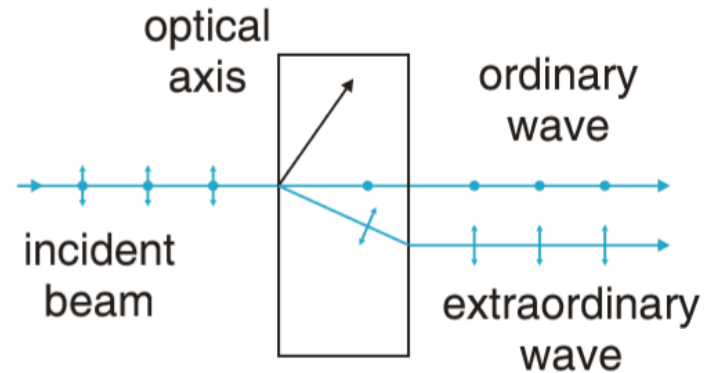
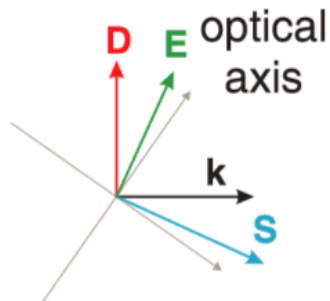

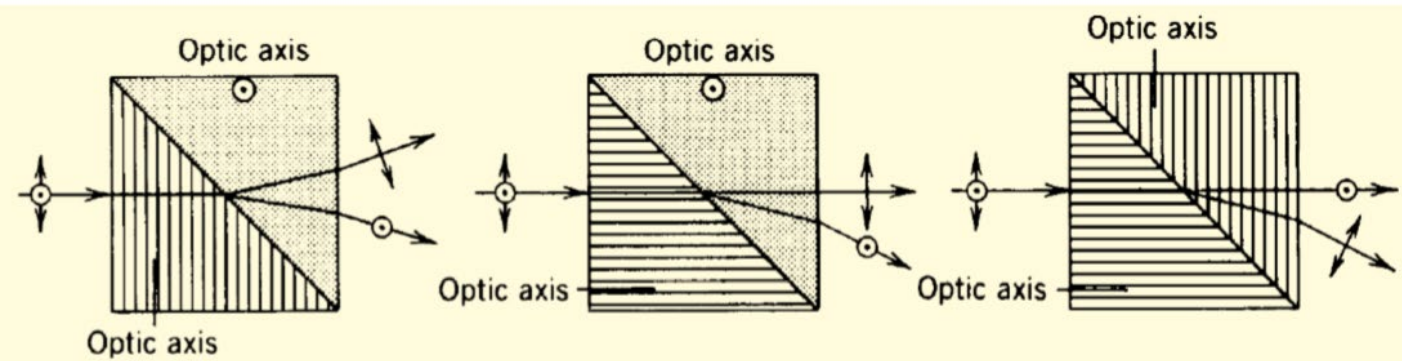
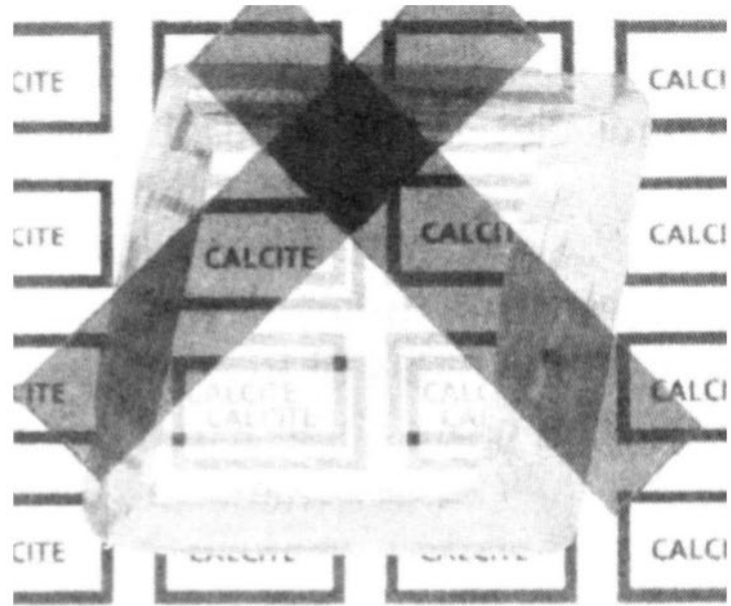



3. retardation

4. electro-optic effect

$$\overleftrightarrow{\epsilon} = \begin{bmatrix} \epsilon_{11}(\mathbf{E}) & \epsilon_{12}(\mathbf{E}) & \epsilon_{13}(\mathbf{E}) \\ \epsilon_{21}(\mathbf{E}) & \epsilon_{22}(\mathbf{E}) & \epsilon_{23}(\mathbf{E}) \\ \epsilon_{31}(\mathbf{E}) & \epsilon_{32}(\mathbf{E}) & \epsilon_{33}(\mathbf{E}) \end{bmatrix}$$

$$\epsilon_{ij}(\mathbf{E}) = \epsilon_{ij}(0) + r_{ijk} E_k + \rho_{ijkl} E_k E_l$$

Pockels effect

Kerr effect





## 5. Pockels cell: polarization modulation

optical switch / amplitude modulation

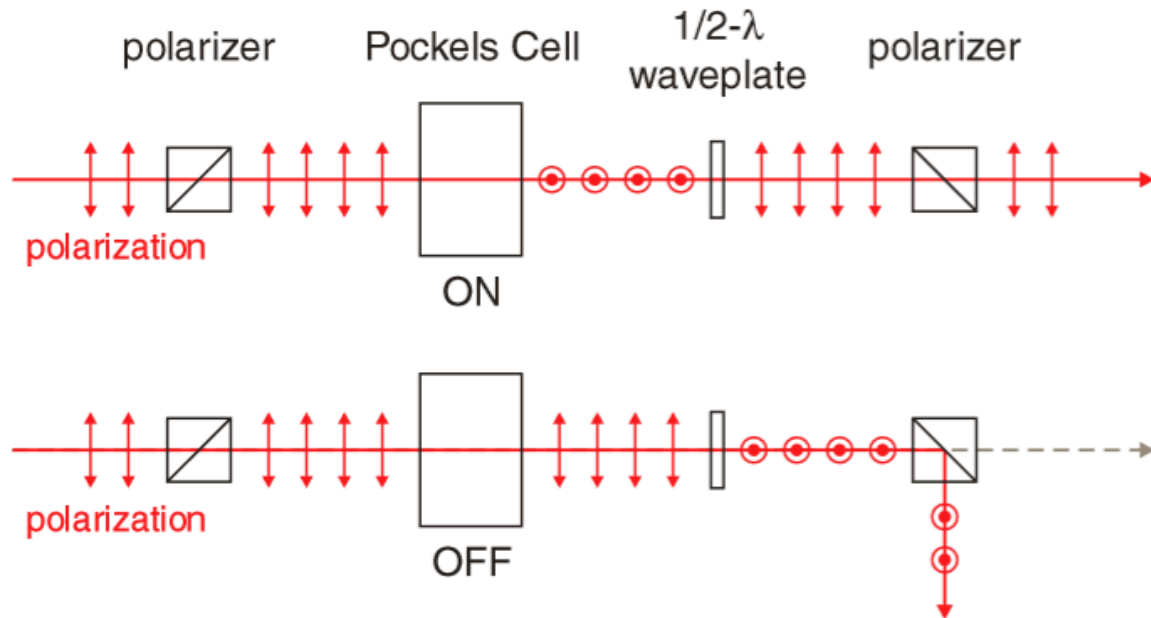



## 6. acousto-optic modulator

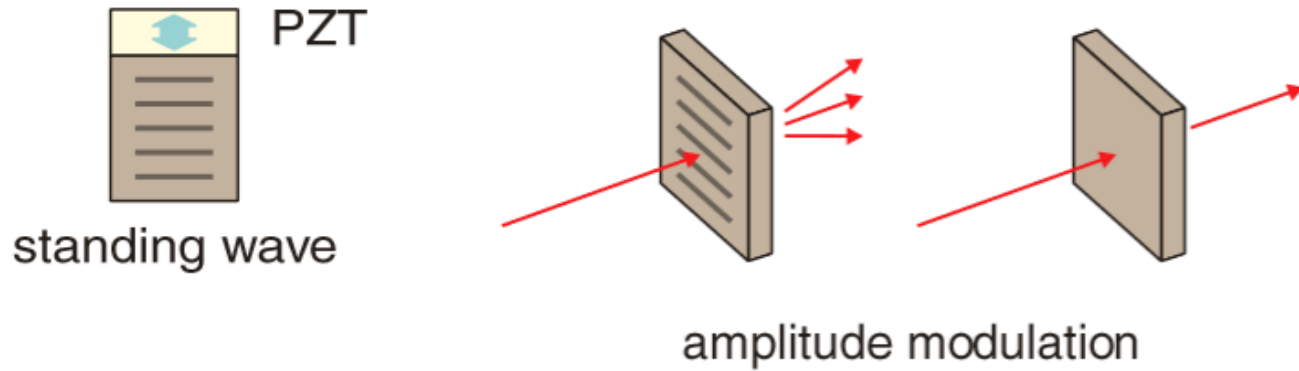

PZT: piezoelectric transducer





# 環形共振腔雷射

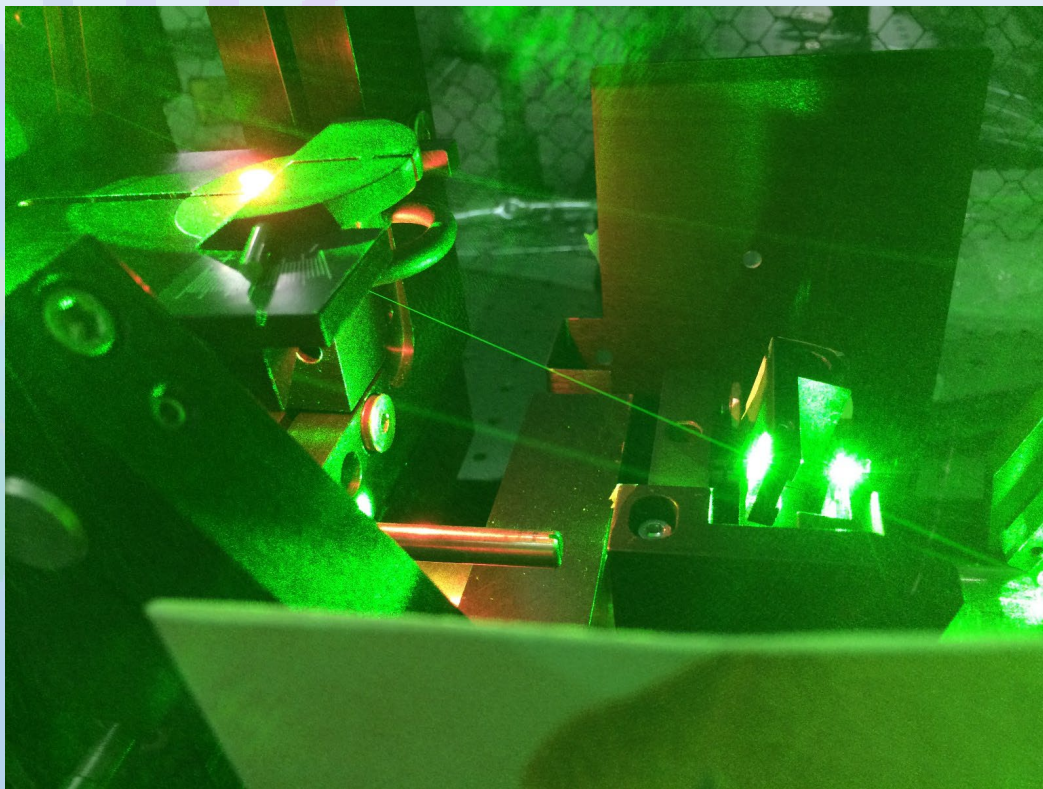



# Q開關雷射

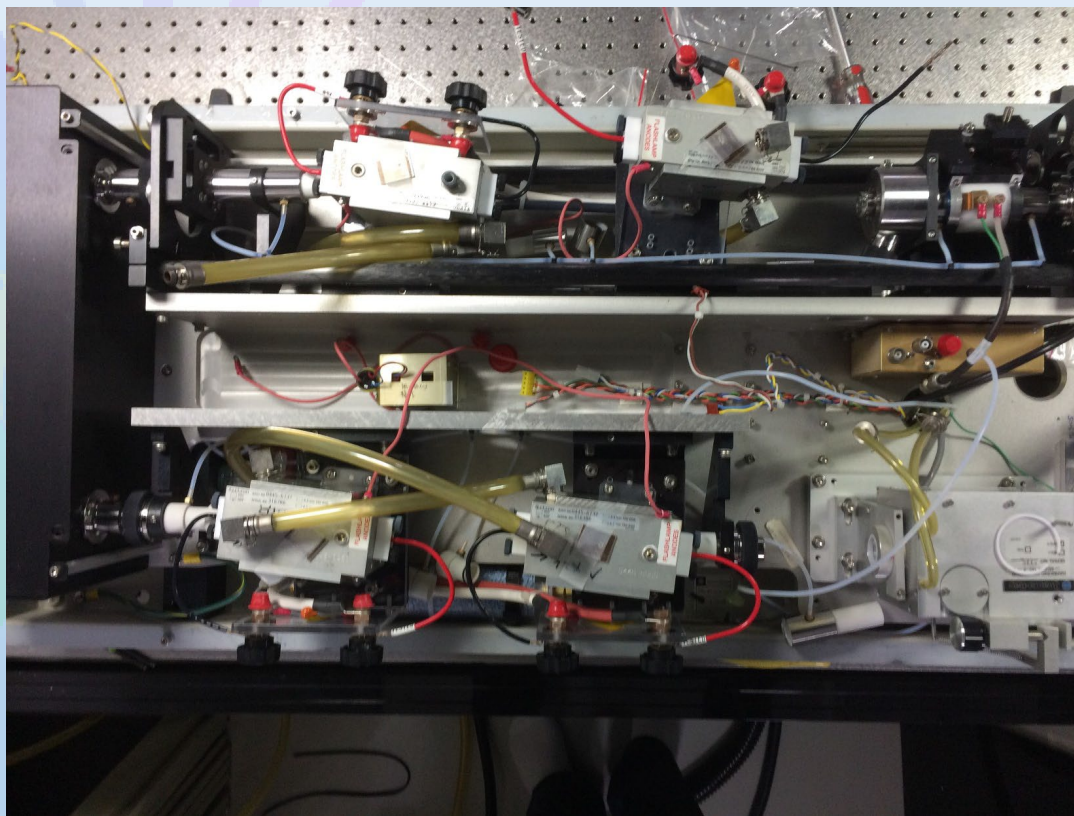



# 鎖模雷射

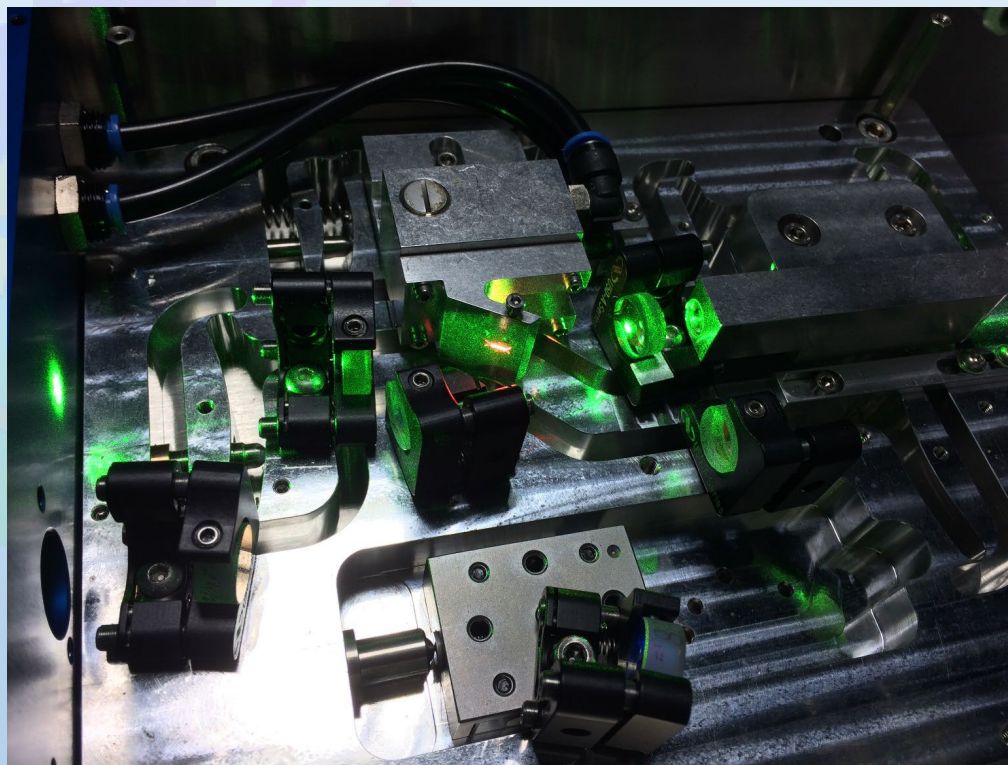

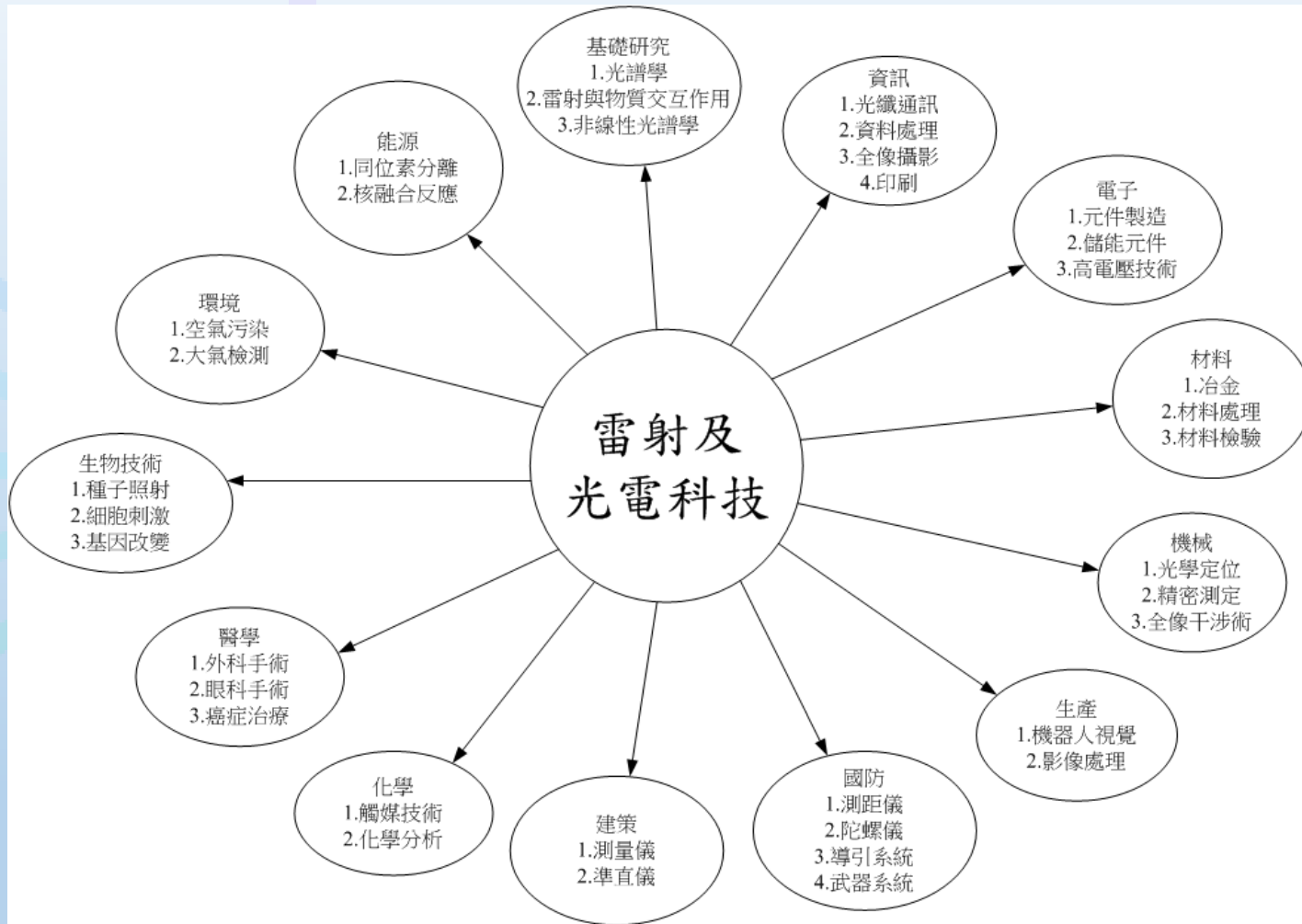

# 光源

非同調光源，D<sub>2</sub> lamp 氙燈，Halogen 鹵素燈  
水銀蒸氣電弧燈

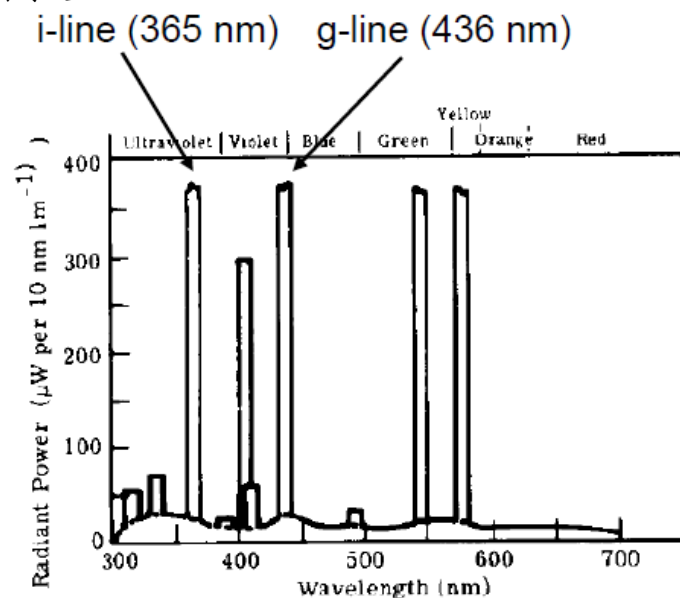
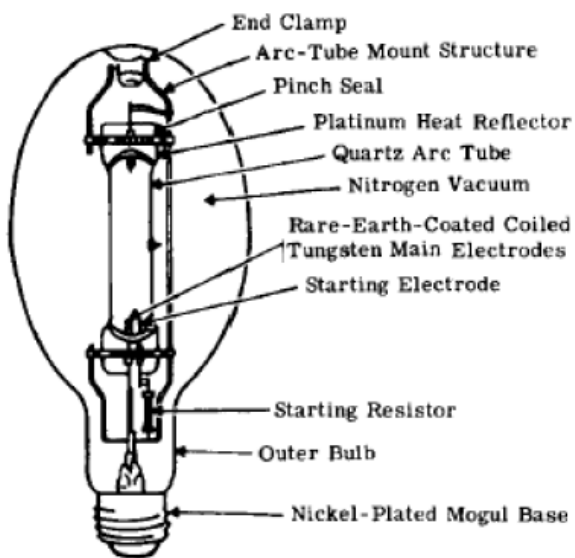
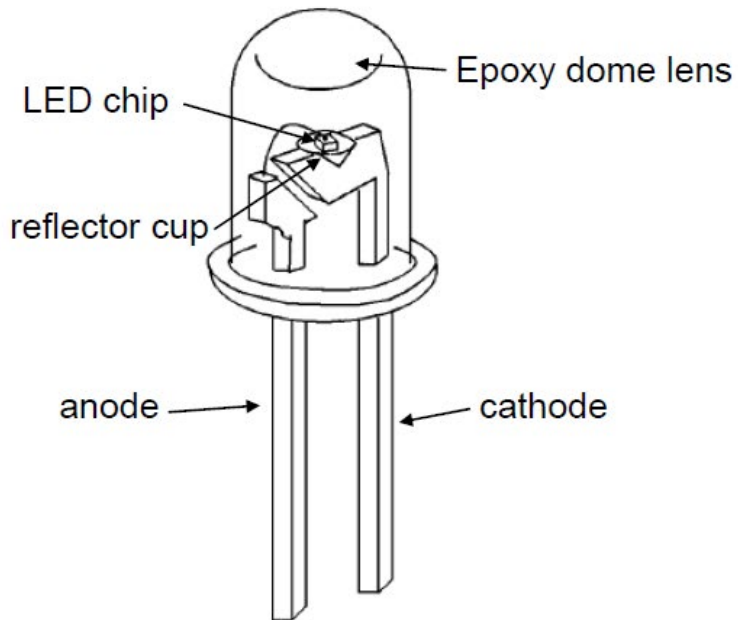

**FIGURE 28** Spectral energy distribution for clear mercury-arc lamp.



# 光源

發光二極體LED





# LED波長分佈

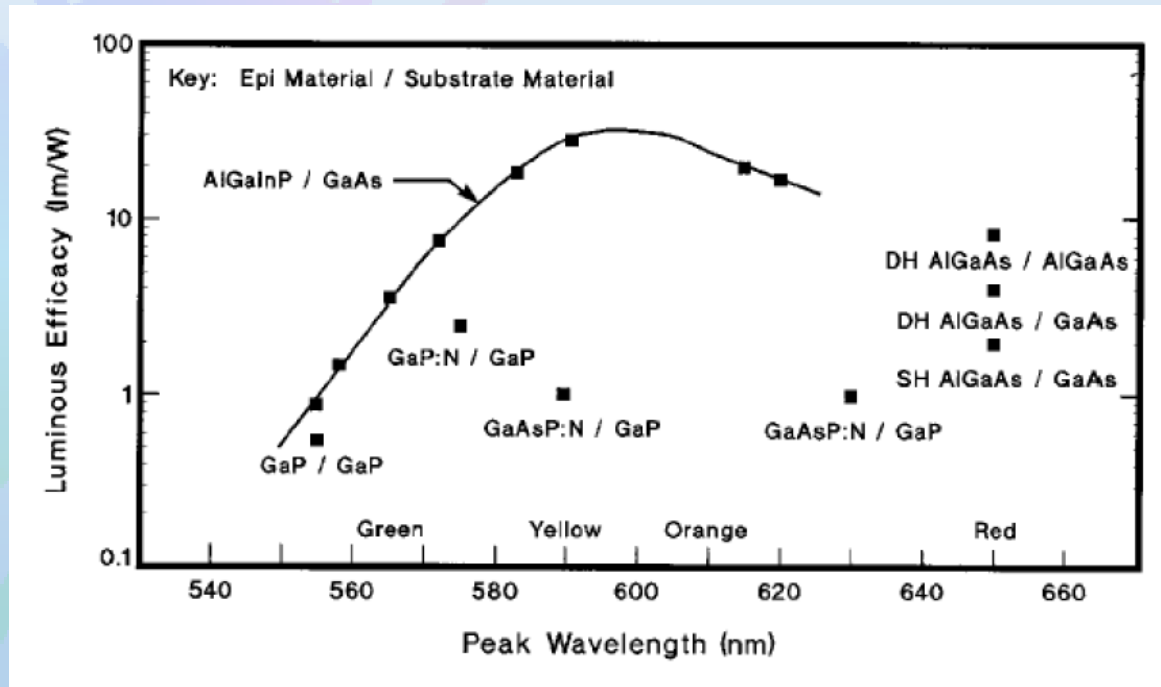



# 光源

雷射已經從實驗室的科研主題延申到的科研工具，再到工廠產業加工工具

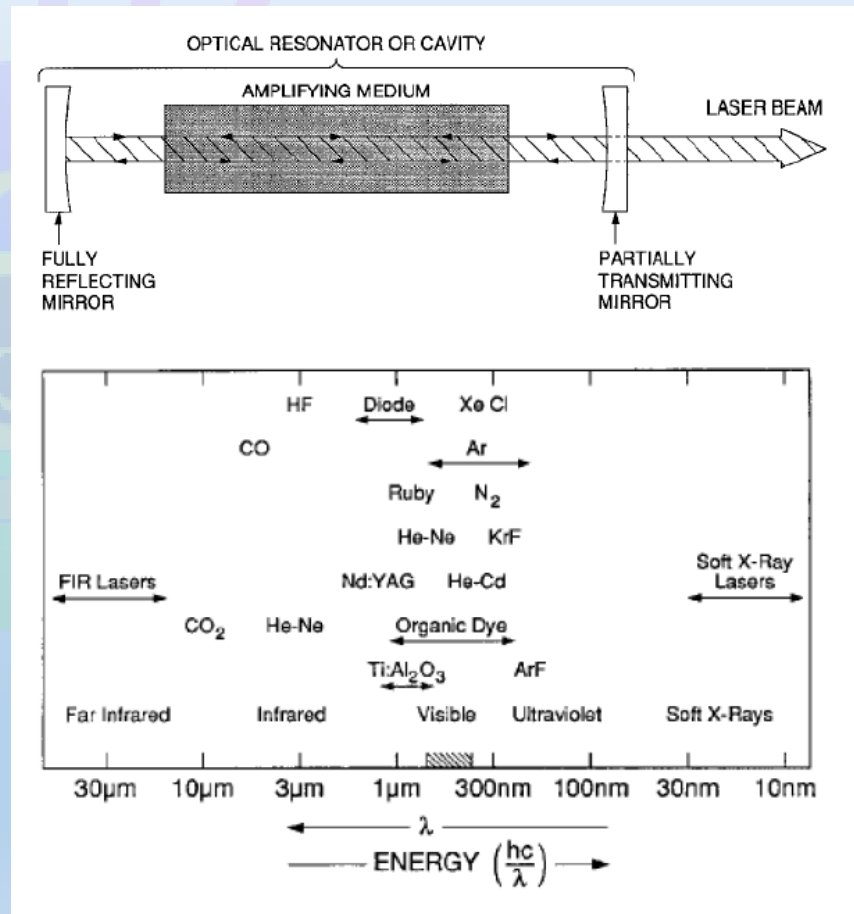

# 二極體激發固態雷射

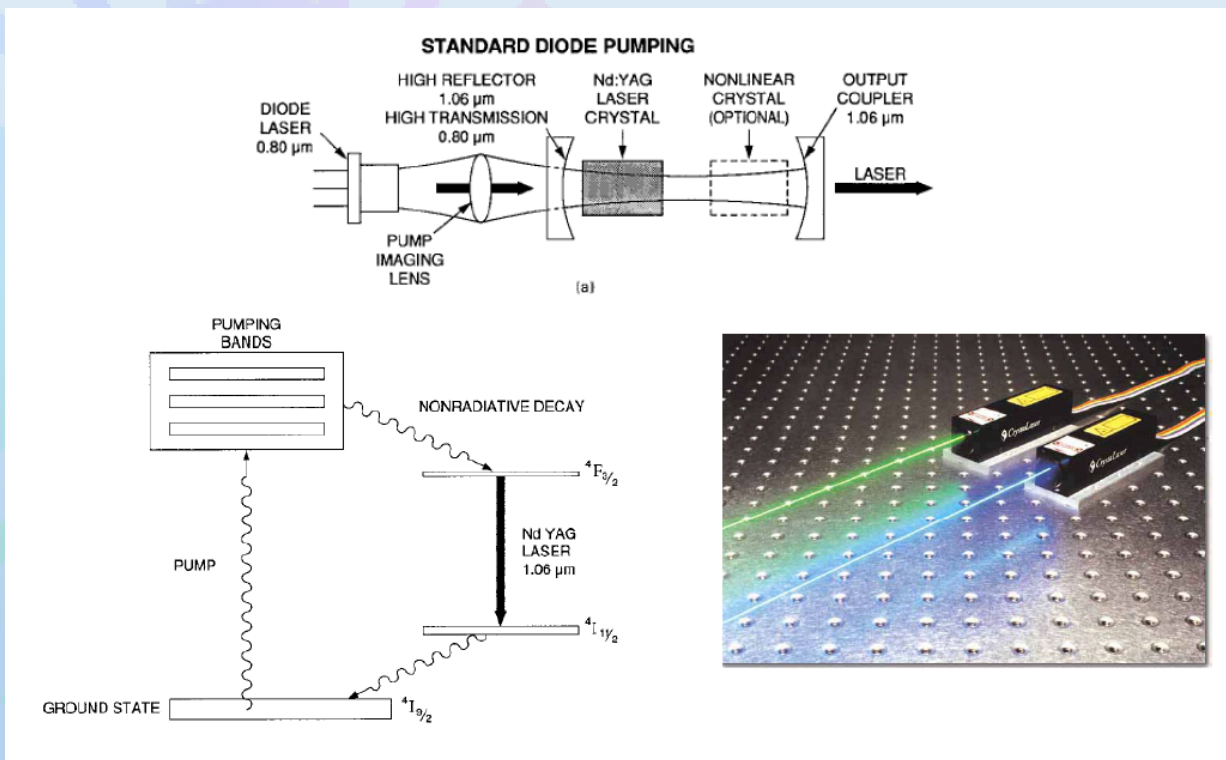

# 准分子雷射

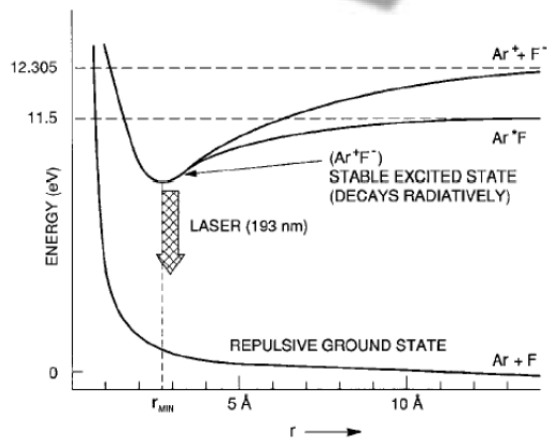

- XeCl: 308 nm
- KrF: 248 nm
- ArF: 193 nm

## Typical Output:

- Pulse duration: 10 – 50 nsec
- Pulse energy: 0.2 – 1.0 J/pulse
- Repetition rate: several hundred Hz





# 各式雷射與輸出波長

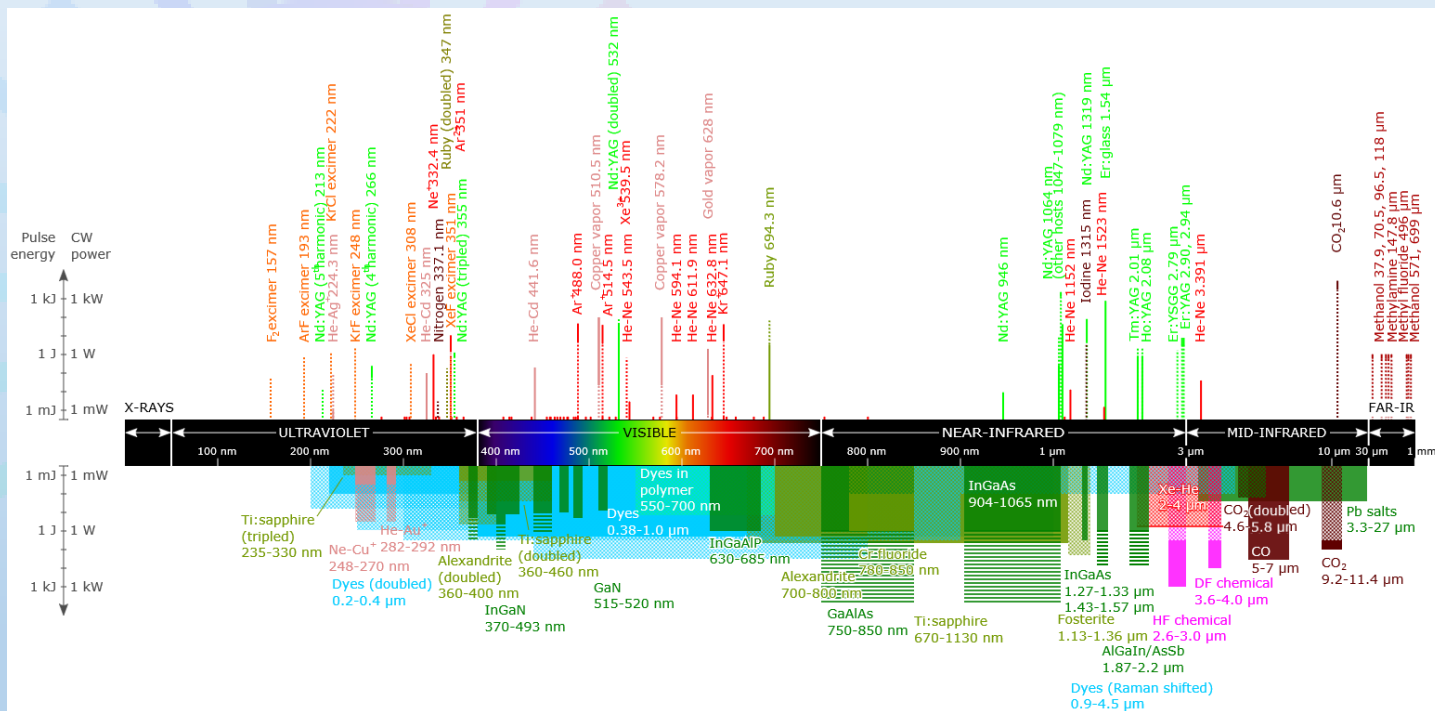

資料來源：維基百科 <https://commons.wikimedia.org/w/index.php?curid=8187485>





# 各式雷射與輸出波長

## 固體

### Semiconductor

InGaN 370-493 nm, 405 nm, 445-465 nm

GaN 515-520 nm

Green diode 510-525 nm

InGaAlP 630-685 nm, 635 nm, 650-660 nm, 670 nm, 760 nm

InGaP 635 nm

GaAlAs 750-850 nm, 785 nm, 808 nm, 1064 nm

VCSEL 850-1500 nm

InGaAs 904-1065 nm, 1.27-1.33  $\mu\text{m}$ , 1.43-1.57  $\mu\text{m}$ , 980 nm

InGaAsP 1310, 1480, 1512, 1550, 1625, 1654 nm

InGaAsN 1310 nm

AlGaIn/AsSb 1.87-2.2  $\mu\text{m}$

GaInAsSb 1877, 2004, 2330, 2680, 3030, 3330 nm

Ce:LiSAF, Ce:LiCAF 280-316 nm

Ruby 694.3 nm

Alexandrite 700-800 nm

Sm:CaF<sub>2</sub> 708.5 nm

Cr fluoride 780-850 nm

Ti:sapphire 670-1130 nm

Laser mice 848 nm

Nd:YLF 1047 nm, 1053 nm

Nd:galss 1062 nm, 1054 nm

Yb:galss 1.0  $\mu\text{m}$

Nd:YVO<sub>4</sub> 1064 nm

Nd:YAG 946 nm, 1064 nm, 1047-1079 nm, 1319 nm

Yb:YAG 1.03  $\mu\text{m}$

Fosterite 1.13-1.36  $\mu\text{m}$

Er:glass 1.54  $\mu\text{m}$

Er-Yb:glass 1.53-1.56  $\mu\text{m}$

Tm:glass 1.8-2.1  $\mu\text{m}$

Tm:YAG 2.01  $\mu\text{m}$

Ho:YAG 2.08  $\mu\text{m}$

Cr:ZnSe 2.2-2.8  $\mu\text{m}$

U:CaF<sub>2</sub> 2.5  $\mu\text{m}$

Er:YSGG 2.79  $\mu\text{m}$

Er:YAG 2.90  $\mu\text{m}$ , 2.94  $\mu\text{m}$

Pb salts 3.3-27  $\mu\text{m}$

Quantum Cascade Mid-IR Far-IR

Raman fiber 1-2  $\mu\text{m}$





# 各式雷射與輸出波長

## 氣體

F<sub>2</sub> 157 nm

ArF 193 nm

KrCl 222 nm

He-Ag<sup>+</sup> 224.3 nm

KrF 248 nm

Ne-Cu<sup>+</sup> 248-270 nm

He-Au<sup>+</sup> 282-292 nm

XeCl 308 nm

He-Cd 325 nm, 441.6 nm

Ne<sup>+</sup> 332.4 nm

Nitrogen 337.1 nm

XeF 351 nm

Ar<sup>2+</sup> 351 nm

Ar<sup>+</sup> 488 nm, 514.5 nm

Copper vapor 510.5 nm, 578.2 nm

He-Ne 543.5 nm, 594.1 nm, 611.9 nm, 632.8 nm, 1152 nm, 1523 nm, 3.391 μm

Xe<sup>3+</sup> 539.5 nm

Gold vapor 628 nm

Kr<sup>+</sup> 647.1 nm

Xe-He 2-4 μm

HF chemical 2.6-3.0 μm

DF chemical 3.6-4.0 μm

CO 5-7 μm

CO<sub>2</sub> 10.6 μm, 9.2-11.4 μm

Free electron laser 0.1 nm - several mm

## 液體

Iodine 1315 nm

Methanol 37.9 μm, 70.5 μm, 96.5 μm, 118 μm

Methylamine 147.8 μm

Methyl fluoride 496 μm

Methanol 571 μm, 699 μm

Dyes (doubled) 0.2-0.4 μm

Dyes 0.38-1.0 μm

Dyes (Raman shifted) 0.9-4.5 μm





# 雷射操作注意事項

- 電源供應
- 冷卻系統
- 安全防護 (goggle/int)

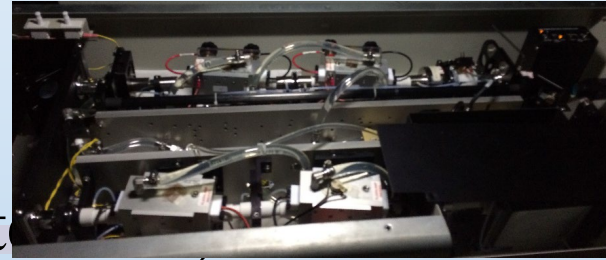



# 雷射操作注意事項

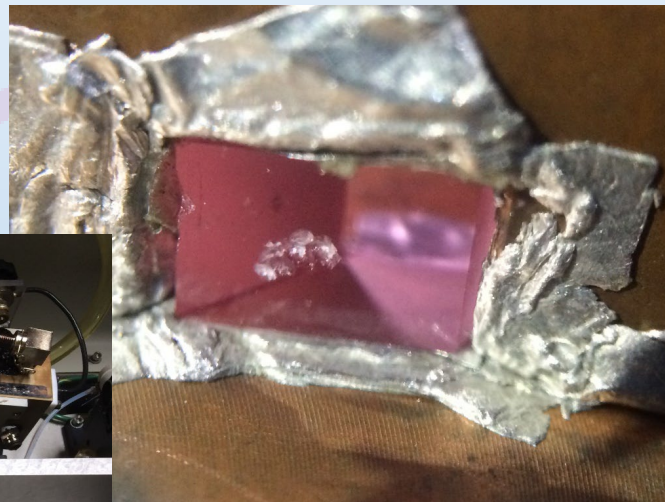
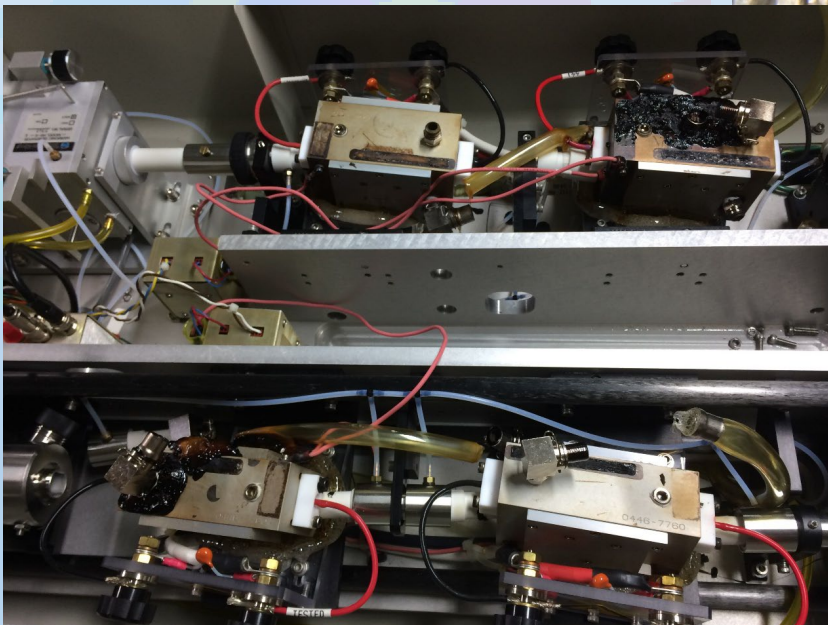



# 光譜儀

- 光柵原理
- 分光儀結構
- 分光儀校正
- 電腦介面控制





# 光柵

- 穿透式，反射式
- 蝕刻光柵， $<1200\text{G/mm}$
- 全像光柵， $>600\text{G/mm}$





# 繞射光柵(閃耀光柵)

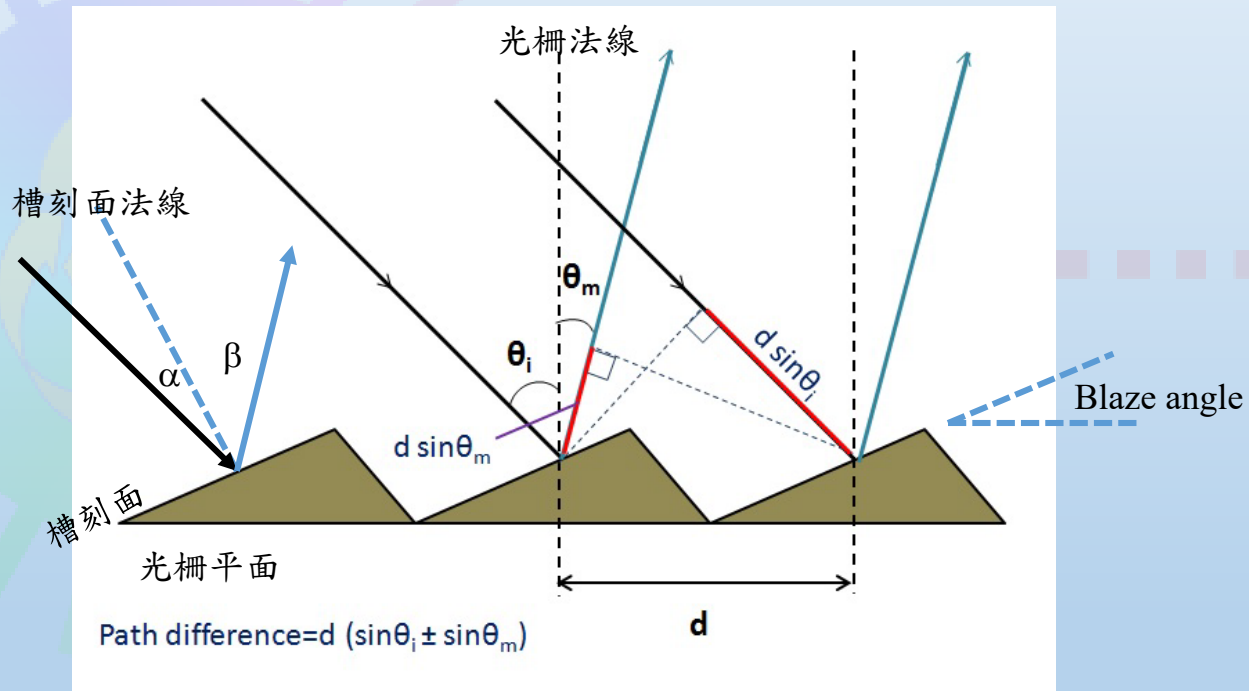

[https://en.wikipedia.org/wiki/Diffraction\\_grating](https://en.wikipedia.org/wiki/Diffraction_grating)





# 光柵公式

$$d(\sin \theta_m - \sin \theta_i) = n\lambda$$

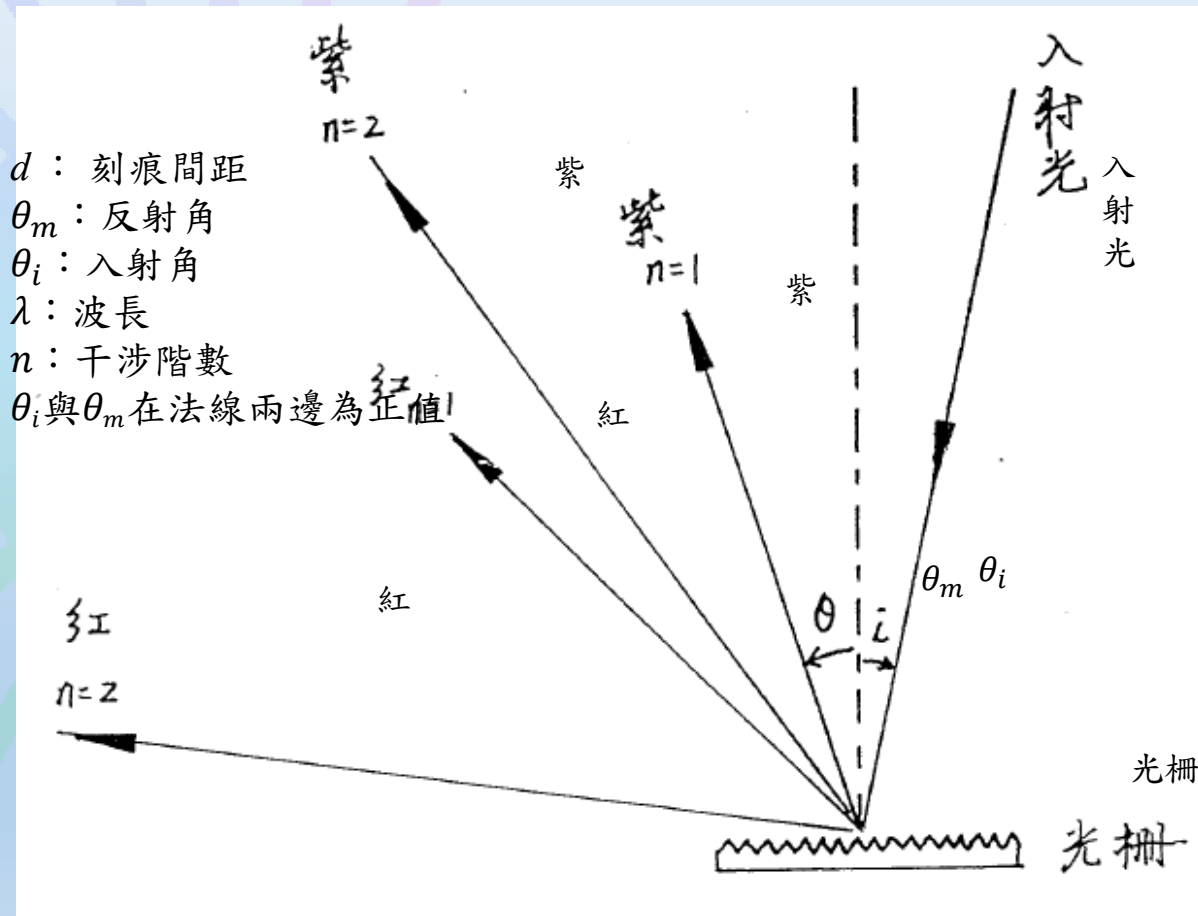

光柵

光柵





# 角解析度 Dispersion

$$d(\sin \theta_{m_0} - \sin \theta_{i_0}) = n\lambda_0$$

$$d(\sin \theta_m - \sin \theta_i) = n\lambda$$

$$\theta_i = \theta_{i_0} - \phi, \quad \theta_m = \theta_{m_0} + \phi$$

$$\theta_{i_0} = \theta_{m_0}$$

$$d \sin \phi (2 \cos \theta_{i_0}) = n\lambda$$

$$d \cos \phi \Delta \phi (2 \cos \theta_{i_0}) = n\Delta \lambda$$

$$\frac{\Delta \lambda}{\Delta \phi} = d \cos \phi (2 \cos \theta_{i_0}) / n$$

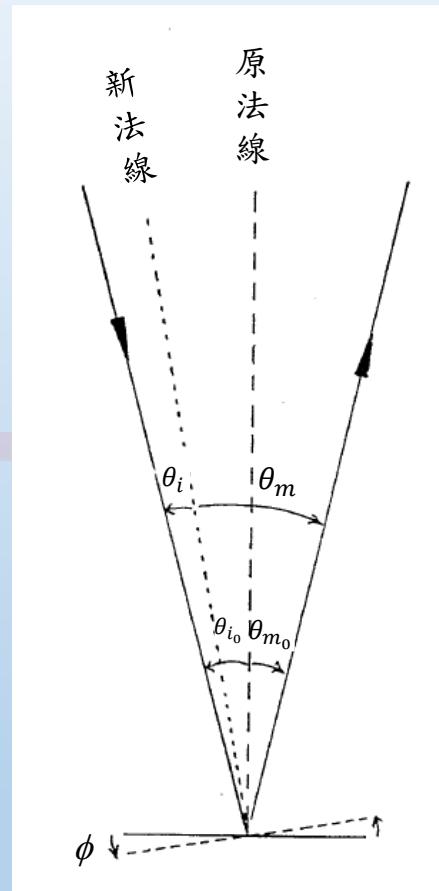



# 光柵解析力 Resolution

$$\frac{\lambda}{\Delta\lambda} = Nn$$

Ex.  $n = 1$ ,  $1200\text{G/mm}$ ,  $5000\text{\AA}$

$$\frac{5000}{N} = \Delta\lambda \quad \text{若光柵為1英吋寬}$$

$$\Delta\lambda = \frac{5000}{N} = \frac{5000}{30480} = 0.164$$

$$f\# (f \text{ number}) = f/D$$





# 分光效率 Efficiency

- $efficiency = \frac{E_{\lambda(grating)}^n}{E_{\lambda(mirror)}}$
- Blaze angle influence efficiency
- $d(\sin \theta_m - \sin \theta_i) = n\lambda \quad \& \quad \alpha = \beta$
- Blaze wavelength







# 正弦桿(sine bar)

$$y = L \sin \phi$$

$$\begin{aligned} n\lambda &= 2(d \cos \theta_{i_0}) \sin \phi \\ &= 2(d \cos \theta_{i_0}) \frac{y}{L} \end{aligned}$$

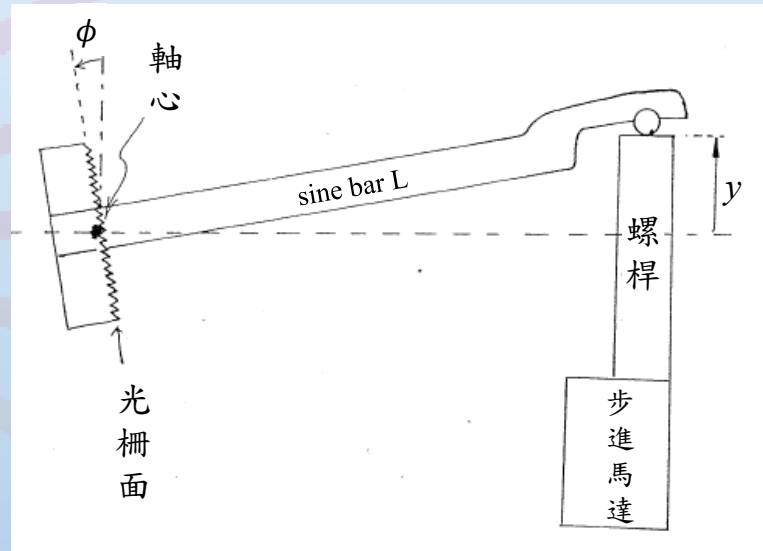



# 分光儀解析度

$\Delta\phi$  光柵轉動角度

$\Delta x = f \times 2\Delta\phi$  在狹縫上移動的距離

$\frac{\Delta\lambda}{\Delta x} = d \cos \phi (\cos \theta_{i_0}) / nf$  分光儀解析度

Ex.  $n = 1, 1200\text{G/mm}, f = 0.5 \text{ m}, \theta_0 \sim 0^\circ$

$$\frac{\Delta\lambda}{\Delta x} = 10^7 \text{ \AA} \cos \phi / (0.5 \times 10^3 \text{ mm} \times 1200)$$

$$\frac{\Delta\lambda}{\Delta x} \sim \frac{100}{6} = 16.67 \text{ \AA/mm}$$





# 分光儀的校正

檢查狹縫

出射光強度

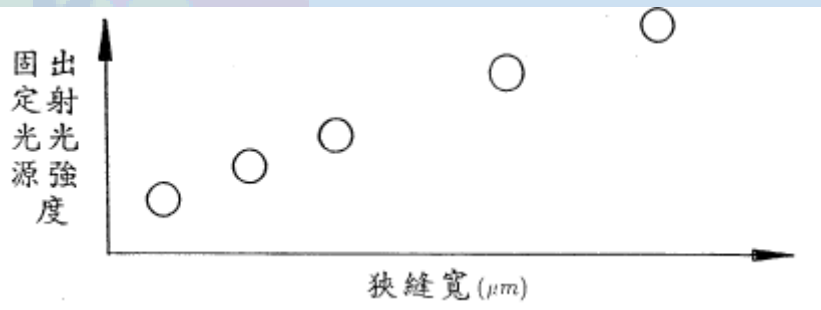

狹縫寬(μm)





# 解析度檢查

- 設定狹縫寬度  $50\mu\text{m}$  ,  $1200\text{G}/\text{mm}$  ,  $f=0.5$
- $\Delta\lambda = 16.667\text{\AA} \times 0.05 \text{ mm} = 0.8\text{\AA}$

## 波長的校正

- 以標準光源(例：汞燈)做波長校正





# 電腦介面控制

- 步進馬達
  - 一般為二相式、三相式或五相式
  - 常用的控制流程是送出時序脈波，然後用解碼方式，依馬達種類編出一序列的脈衝送出。轉動方向是由另一邏輯訊號控制。
  - 馬達推動線路包括解碼與放大電流。控制部份只需送出時序脈衝和方向邏輯即可。



# 拉曼光譜儀

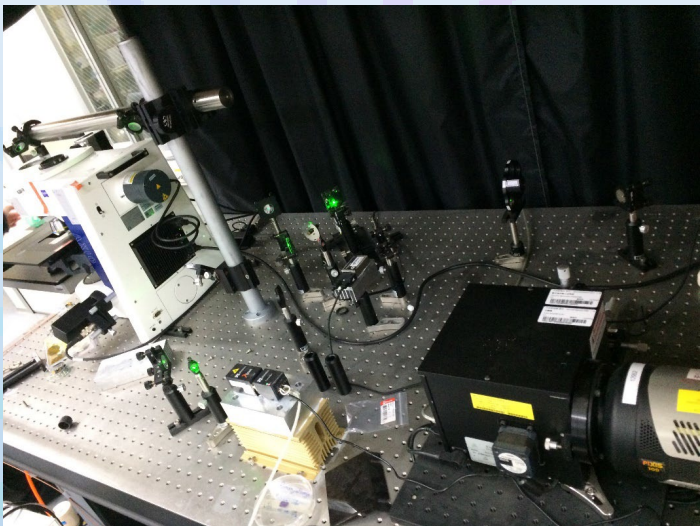

原分所謝雅萍老師實驗室

原分所共用儀器實驗室

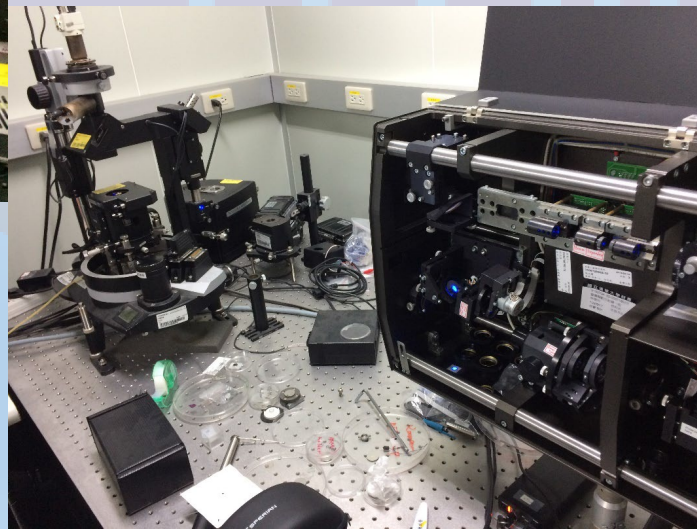



# 共軛焦顯微鏡

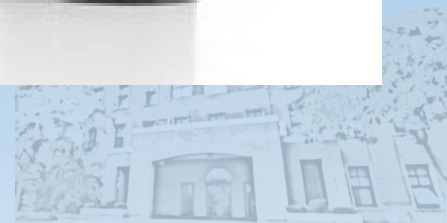



# 共軛焦顯微鏡原理

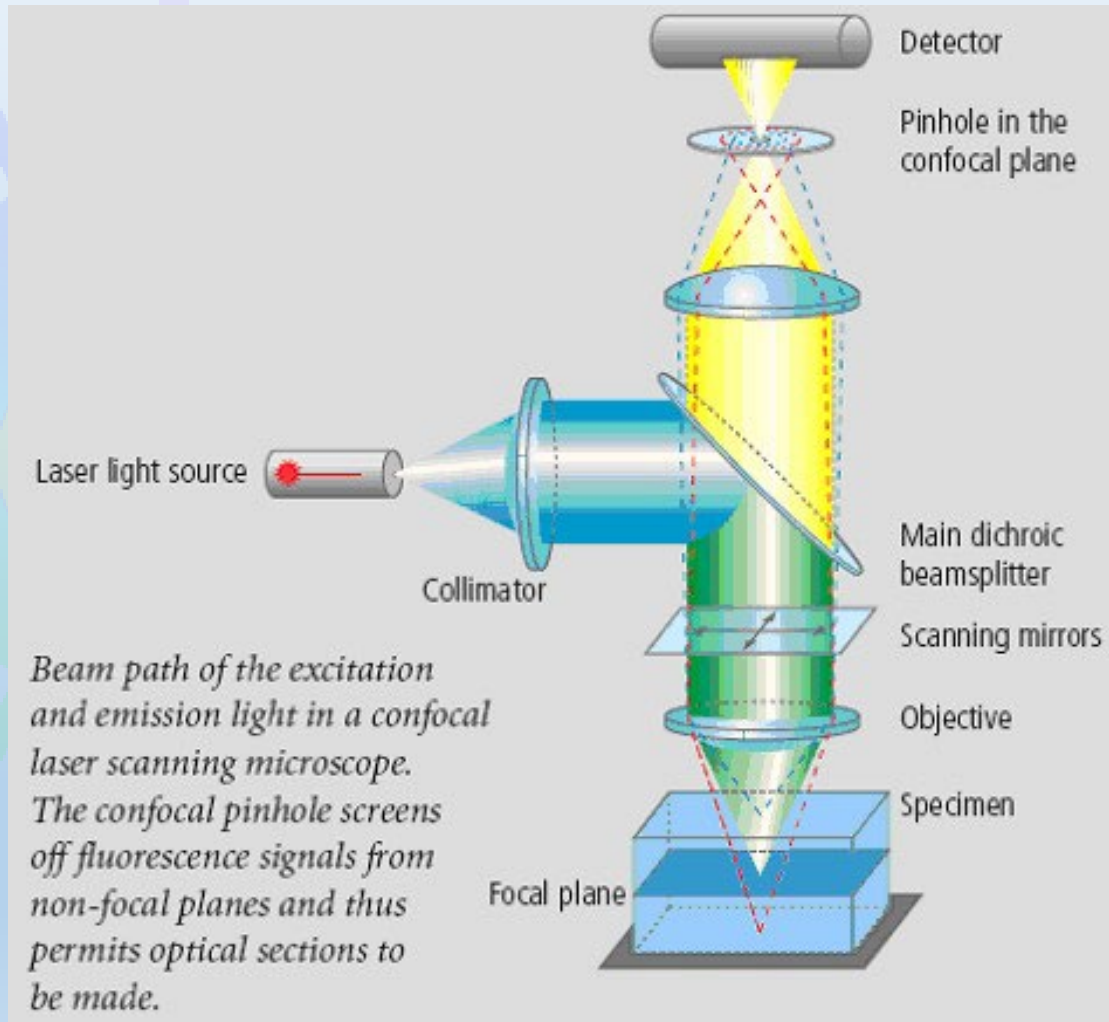



# 原分所共用儀器(生物物理)

## 1. Cell culture

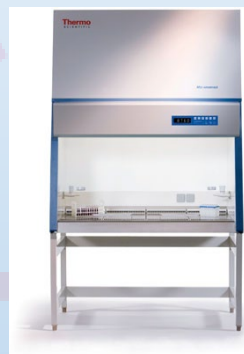
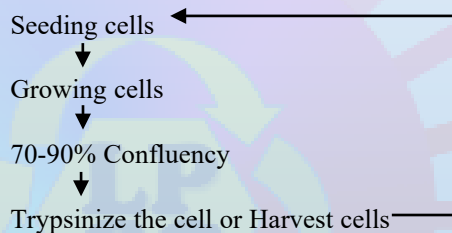

Thermo: model 1375  
120V, 50/60Hz  
1568(H) x 1300(W) x 800(D) mm

## 2. Nucleic acid / Protein purification

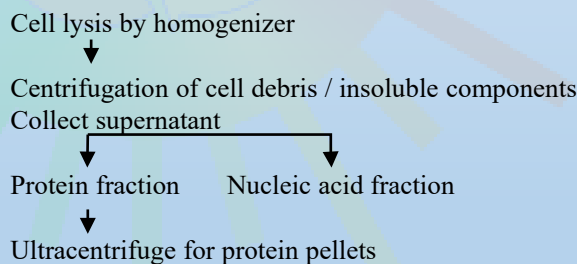

Beckman: XPN-100  
200-240V, 30 A, 50/60 Hz  
1257(H) x 940(W) x 681(D) mm





# 原分所共用儀器(生物物理)

## 3. Protein identification

CD spectrum  
(Circular dichroism)



Jasco: J-715  
120V,

MALDI-TOF spectrum  
(matrix-assisted laser desorption ionization-time of flight)



Bruker: microflex LT/SH  
~100 to 230 V / 3-1.5 A / 50-60 Hz

## 4. Nucleic acid quantification

Real-time PCR

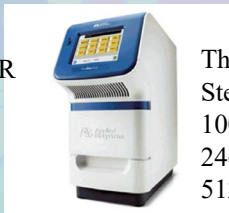

Thermo:  
StepOnePlus  
100VA, 50/60 HZ  
246(W) x 427(D) x  
512(H) mm

Absorption / Fluorescence / Luminescence spectrum



Promega: GloMax GM3000  
120VA, 50/60 HZ  
469(W) x 465(D) x 355(H)  
mm

## 5. Fluorescence images

Confocal Microscopy SP8



Leica: Confocal SP8X  
~100 to 240 V / 50-60 Hz





# 原分所共用儀器(尖端材料)

SEM & EDX

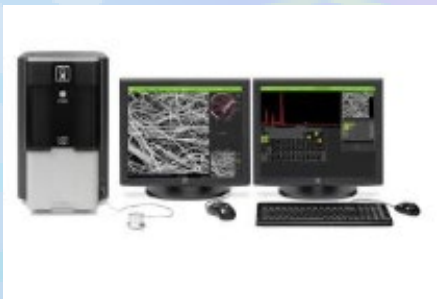

TGA/DSC

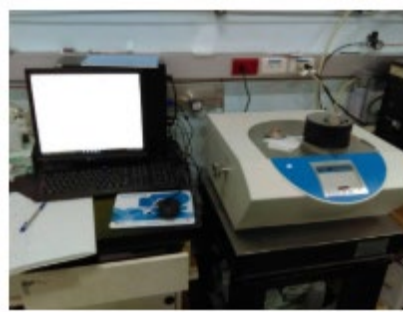

TPD/TPR/TPO



FT-IR

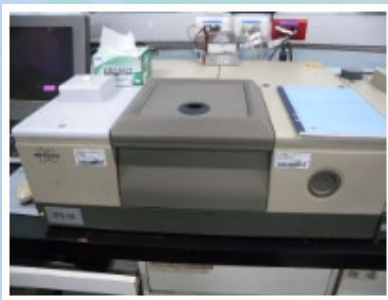

Raman/AFM



X-ray fluorescence



# 光學桌

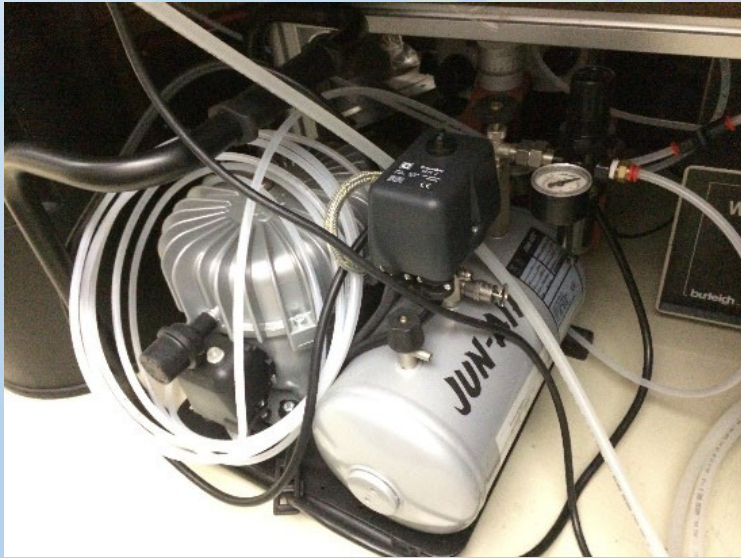

# 溫度控制





# 參考資料

- 實用真空技術 呂登復 國興出版社
- 雷射工程導論 丁勝懋 中央圖書出版社
- The official website of the Nobel Prize  
<https://www.nobelprize.org/>
- 中央研究院原子與分子科學研究所暨國立中央大學物理系，強場物理與超快技術實驗室 暑期新生訓練講義。  
<http://hfp.phy.ncu.edu.tw/訓練/暑期新生訓練>

