



控制

2022基礎實驗技術訓練

雷射光電支援中心

陳蔚然





控制

● 基本概念

● 工具儀器

- 控制儀器：函數（任意波形）產生器、脈衝延遲產生器、PID控制器、AD/DA、DAQ
- 通訊介面：RS232、GPIB、USB、Ethernet
- 致動儀器：移動平台、馬達、壓電驅動器、空油壓、機電控制

● 程式設計

- LabVIEW
- Arduino單晶片微控制器
- 案例：LabVIEW+Arduino、光束穩定控制、光束特性測量、超快雷射脈衝測量與調控

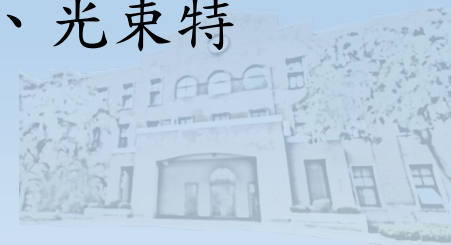



控制系統

- 依有無回授作用分類
- 開路控制系統 (Open-loop control system)

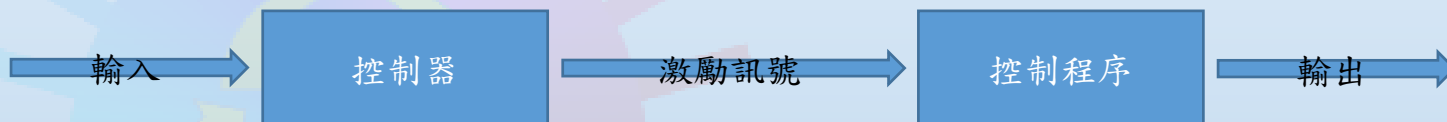

- 閉路控制系統 (Closed-loop control system)

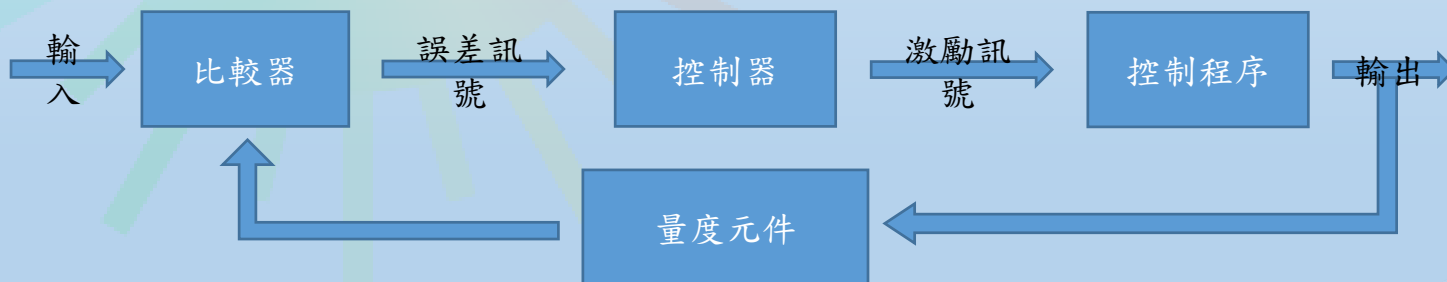



回授控制系統方塊圖

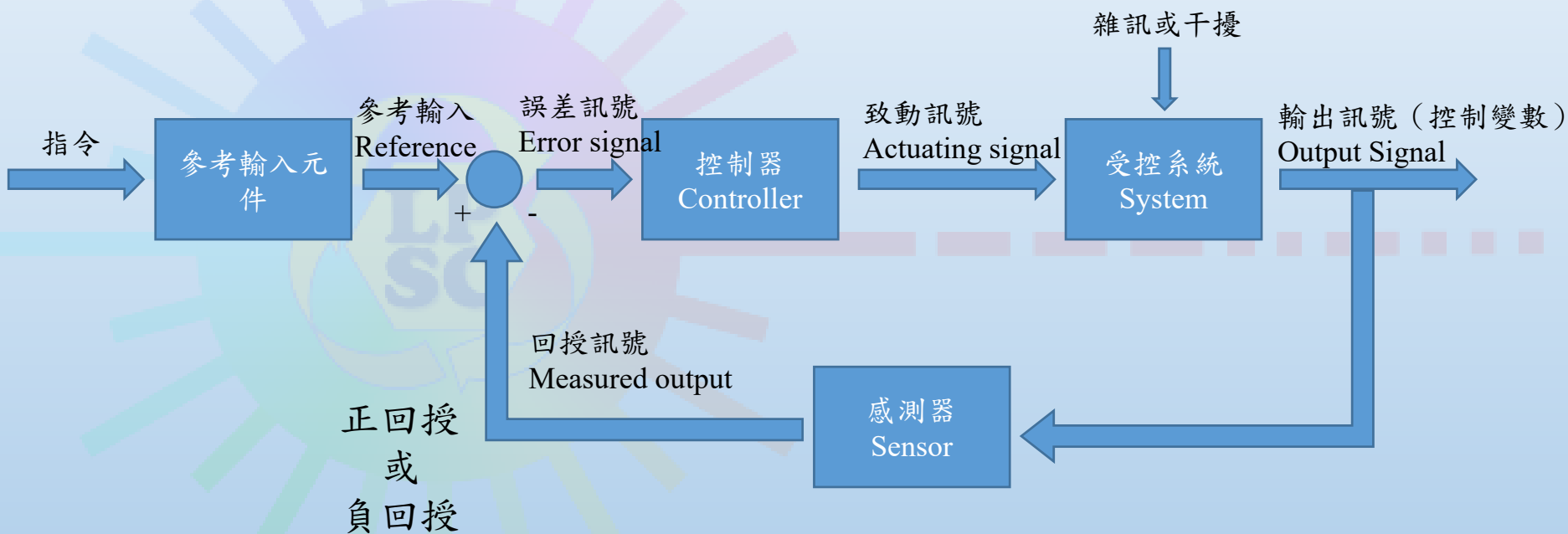



回授控制系統種類

- 依控制變數可分為伺服機構(servo mechanism)、程序控制(process control)及自動調整(automatic regulation)三大類。

控制名稱	控制變數
伺服機構	機械位置，角度，速度
程序控制	化工溫度，壓力，流量，液面，濕度
自動調整	電壓，電流，電力

- 依訊號在系統中的型式，又可分為連續資料(continuous-data)及離散資料(discrete-data)系統。

控制名稱	系統訊號型式
連續資料	連續時間函數
離散資料	脈波序列或數位碼





計算機控制系統 VS 類比控制系統

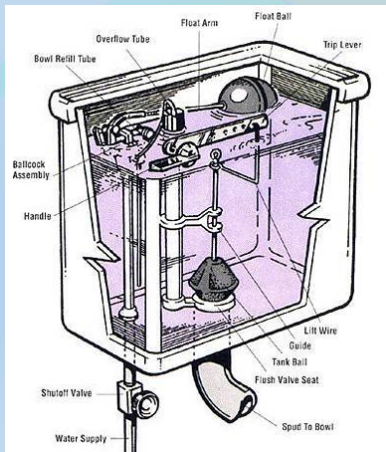
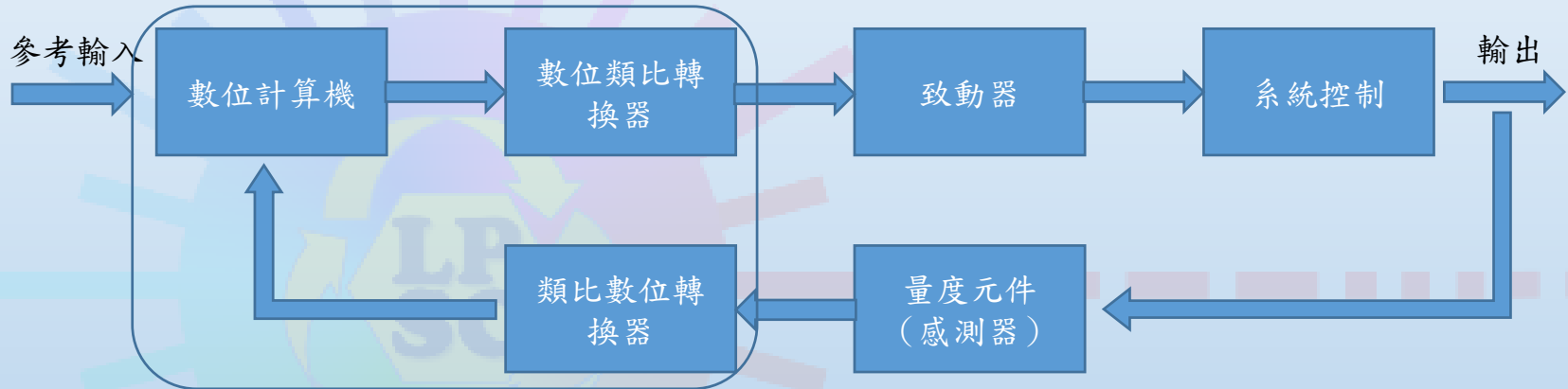

圖片來源: "How to Repair a Toilet." HowStuffWorks. (accessed Apr. 12, 2012).
<<http://home.howstuffworks.com/home-improvement/plumbing/how-to-repair-a-toilet3.htm>>





控制器

- 雙位置或開關控制器 (two-position or on-off controller)
- 比例控制器 (proportional controller)
- 積分控制器 (integral controller)
- 比例積分控制器 (proportional-integral controller)
- 比例微分控制器 (proportional-derivative controller)
- 比例積分微分控制器 (proportional-integral-derivative controller)





控制器致動方式

- 電子式控制器 (electronic controller)
- 氣壓式控制器 (pneumatic controller)
- 油壓式控制器 (hydraulic controller)





控制系統的研究與設計

研究步驟	意義	相關內容
建立模型(modeling)	尋找一個和系統特性相似且易於研究的模型	物理系統的數學模式 狀態變數分析
數學描述 (mathematical description)	建立數學方程式描述此模型	
分析(analysis)	定量：系統對於輸入及初始條件的確切響應（或輸出行為）	狀態變數分析 離散資料系統 時域特性分析 頻率響應法 頻域特性分析
	定性：穩定性，控制性，觀測性，靈敏度等	狀態變數分析 靈敏度和穩定性 根軌跡法 頻率響應法 頻域特性分析
設計(design)	分析系統那些不符合規格要求後，調整系統參數或加入補償器	控制系統的設計與補償



轉移函數(物理系統的數學模式)

- 線性非時變系統初始條件皆為零時 $c(t)=F(r(t))$
- 轉移函數 $G(s)=L(c)/L(r)$

$$L(c(t)) \rightarrow c(s); L(r(t)) \rightarrow r(s)$$

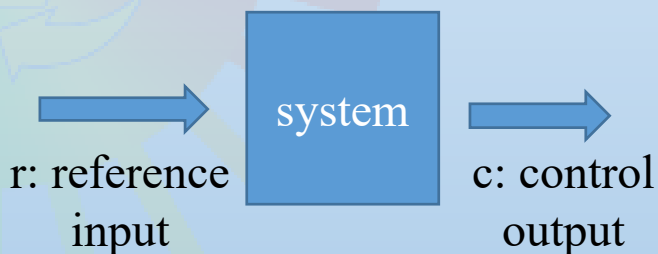



方塊圖

為系統中每一元件之功用及訊號流向之圖示，和轉移函數一起用來表示整個系統的因果關係

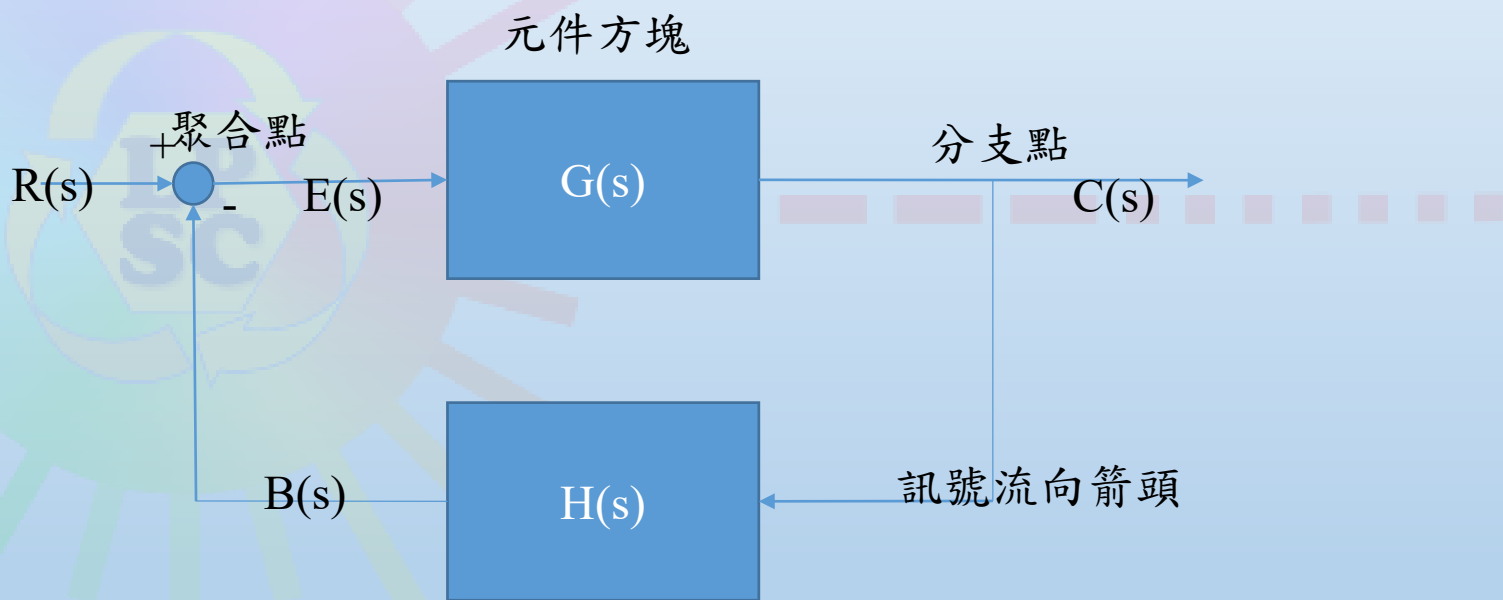

方塊圖代數：串聯，並聯





訊號流程圖

訊號流程圖為描述線性系統一組代數方程式，其變數間輸入與輸出的關係之圖解法

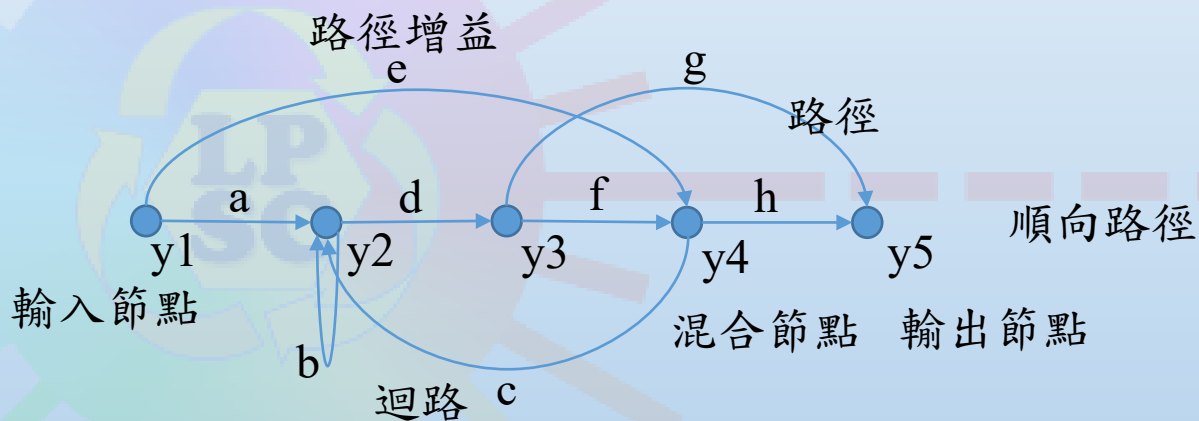

訊號流程圖代數

1. 加法
2. 乘法
3. 迴路





狀態變數分析

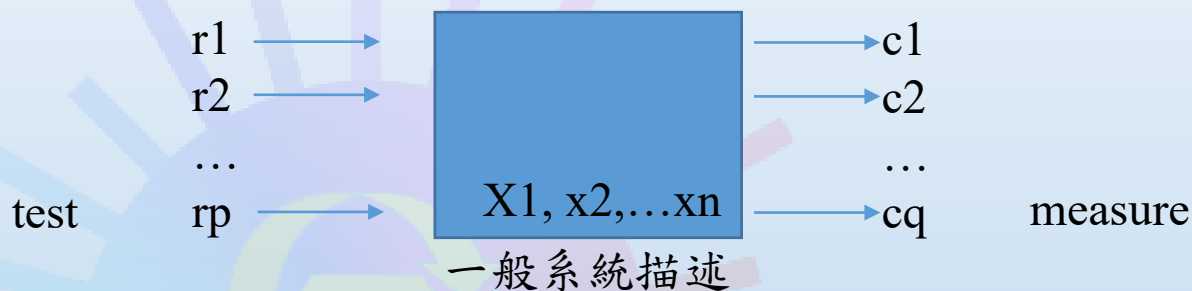

狀態方程式 $\dot{X}(t) = Ax(t) + Br(t)$
輸出方程式 $c(t) = Dx(t) + Er(t)$

系統的控制性和觀測性

微分方程描述連續資料（拉氏轉換）或類比訊號
差分方程描述離散資料（Z轉換）或數位訊號





控制系統的時間響應

- 暫態響應
- 穩態響應
- 線性系統分析中常將系統性能評估分為三個領域

性能評估	性能指標
時域	a上升時間與最大超越量，b安定時間，c穩態誤差
複域	a阻尼比，b阻尼常數
頻域	

- 穩態誤差來自系統元件的非線性特性，數位元件如微處理器的量化，放大器的漂移及靜態的摩擦等





時間響應

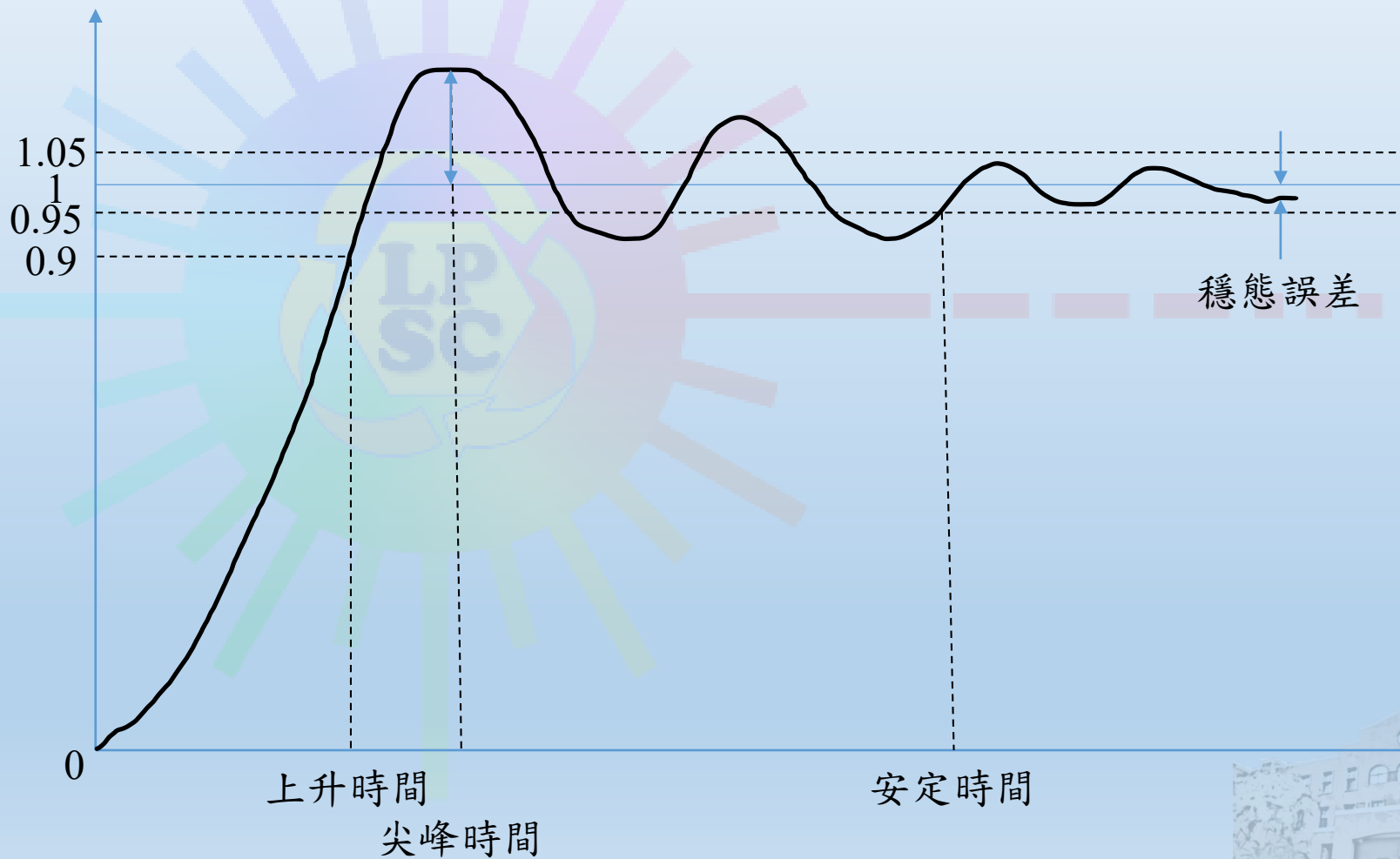

穩態誤差

上升時間

尖峰時間

安定時間





靈敏度 Sensitivity

系統中參數的改變，對系統特性影響程度的一種量度。
定義：系統轉移函數的變化率與系統參數的變化率之

比 $M(s)$ 為系統轉移函數 $S_K^M = \frac{\Delta M / M}{\Delta K / K}$





穩定性

系統的穩定性是由其對於輸入或干擾所產生的響應來決定。穩定系統意指系統在外加激勵不產生響應，而在所有激勵源除去後，將又回復至原來靜止狀態。

時域上定義：1. 系統脈衝響應隨時間趨近於無窮大而趨近於零。2. 有限的輸入產生有限的輸出。

分為

絕對穩定性

相對穩定性：穩定程度的測定





根軌跡法

- 開路系統之暫態響應及相對穩定性與特性方程式的根在 s 平面上位置有直接關係，若系統中有一參數改變，特性根亦將改變，在古典控制的設計中，往往會調整此參數甚至加上補償器以使特性根在所要的位置得到理想工作性能。
- 根軌跡法root locus method是以系統增益作函數繪出閉路系統特性根在 s 平面上位置的軌跡。





頻率響應

為系統對正弦輸入訊號的穩態響應。線性非時變穩定系統輸入一正弦訊號，暫態完全消失後的穩態輸出與輸入相同頻率但相差一相位角的正弦函數

$$r(t) = R \sin(\omega t); c(t) = C \sin(\omega t + \phi), \frac{C(s)}{R(s)} =$$

$$\frac{G(s)}{1+G(s)H(s)}$$

優點 1. 以正弦訊號產生器利用實驗方法易於取得系統的頻率響應。2. 系統轉移函數可藉由頻率轉移函數令 $i\omega = s$ 而獲得。3. 系統絕對穩定性和相對穩定性容易分析且較實用。4. 可設計得不受雜訊干擾的系統。





頻域特性分析

- 奈氏穩定準則是利用開路轉移函數的頻率響應，決定閉路系統穩定性之圖解法。

LP
SC





控制系統的設計與補償

控制系統設計的基本原則在於符合性能規格，大致指出 1. 響應速度，2. 相對穩定性，3. 系統精確度或容許誤差。在時域中常見規格說明有安定時間 $t_s(2\%)$ ，自然無阻尼頻率 ω_n ，最大超越量，阻尼比 ζ 及誤差常數。在頻域中常見的規格說明有尖峰共振 M_p ，共振頻率 ω_p ，增益邊限G.M.及相位邊限P.M.。

設計好的控制系統應檢視是否滿足系統要求。若非如此，則應調整系統中可變參數或改變系統結構。此改變或調整以提供滿意的工作性能稱為補償

(Compensation) 因補償而加入系統元件稱為補償器 (Compensator) 可為電機式、機械式、氣壓式、油壓式或其組合

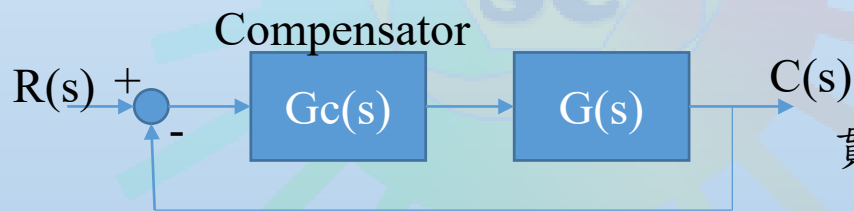

貫聯或串聯補償 (簡單，通常需額外隔離放大器)

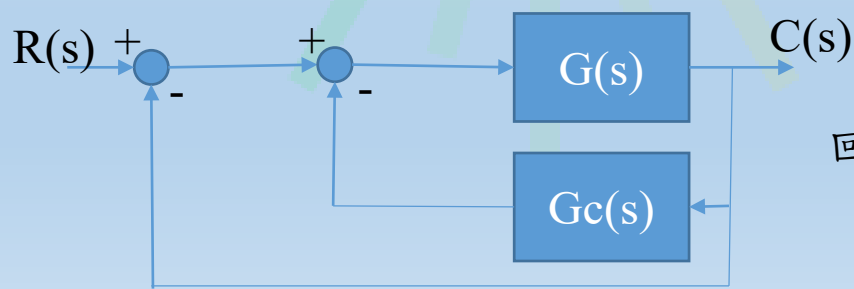

回授或並聯補償





PID控制器

$$G_c(s) = K_P + \frac{K_I}{s} + K_D s$$

比例：實際上為一可調增益放大器，可改善系統靈敏度及精確度，但卻降低系統相對穩定性。

積分：增加一在原點的極點，可改善穩態誤差，但卻也使系統可能變得不穩定。

微分：可改善系統阻尼特性及穩定性，但過大微分動作使系統變為過阻尼。

設計PID控制器必需決定 K_p 、 K_i 、 K_d 參數，使系統滿足性能要求。

紫雅格-尼可士 (Ziegler-Nichols) 1942提出 $G_c(s) = K_P \left(1 + \frac{1}{T_I s} + T_D s \right)$

比例增益

微分時間

重置時間

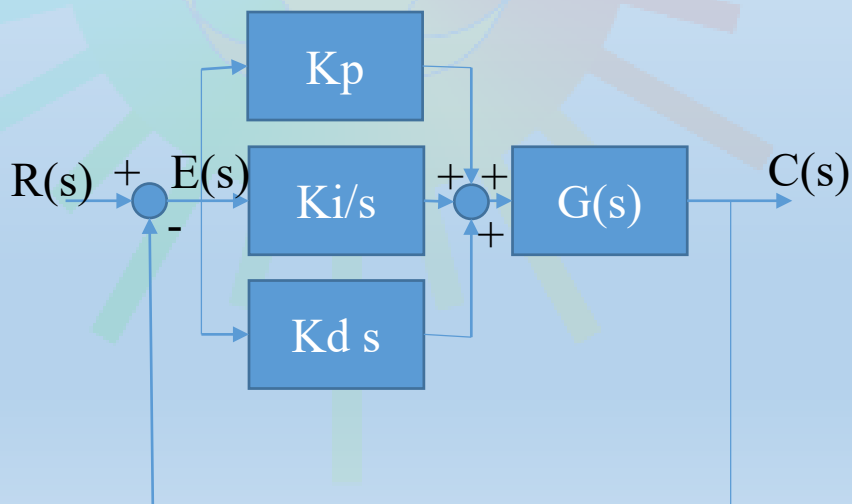



控制儀器

- 函數（任意波形）產生器、脈衝延遲產生器、PID控制器、AD/DA、DAQ

LP
SC





函數產生器

- 一般函數產生器
- 任意波型產生器



脈衝延遲產生器

- 4 pulse outputs
- 8 delay outputs (opt.)
- Less than 25 ps rms jitter
- Trigger rates to 10 MHz
- Precision rate generator
- Fast transition times
- Ovenized or Rb timebase (opt.)
- Ethernet, GPIB & RS-232

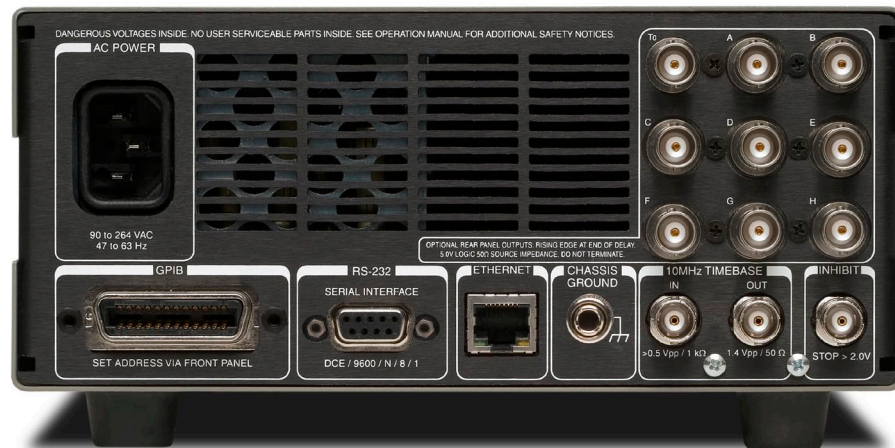



AD/DA card

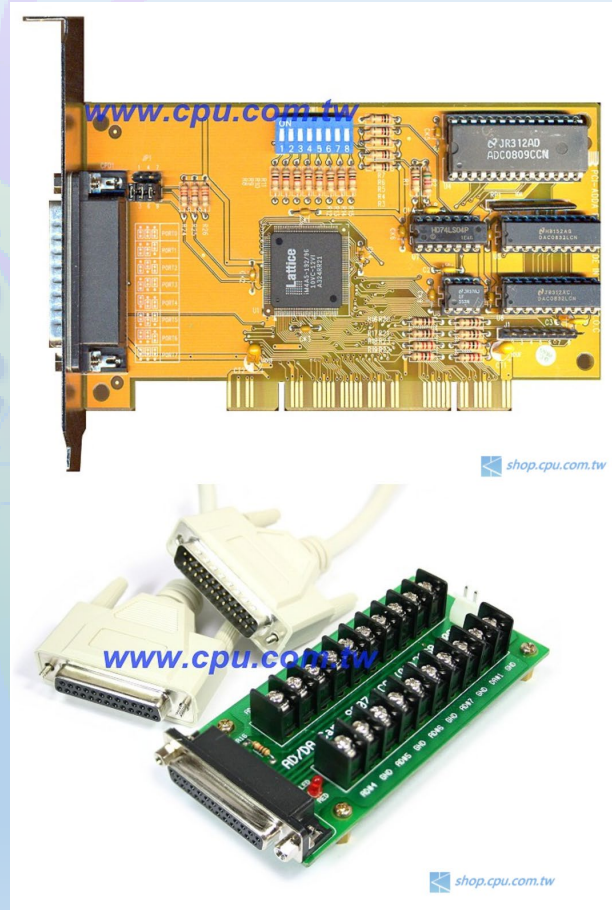



NI-DAQ



<https://www.ni.com/zh-tw.html>





傳輸介面

- 電腦與儀器連線：RS232、GPIB、USB、Ethernet





Data transmission between computers and instruments

- Serial port (RS-232)
 - Simple
 - Low transfer rate
 - Long distance
- GPIB (general purpose interface bus)
 - 1MB/s transfer rate
 - Short distance
 - Complex and expensive



RS-232

設定：
鮑率Baud rate
同位檢查Parity
停止位Stop bit
流量控制

RS232 Pinout

Pin 1: Data Carrier Detect (DCD)
Pin 2: Received Data (RXD)
Pin 3: Transmit Data (TXD)
Pin 4: Data Terminal Ready (DTR)
Pin 5: Ground (GND)

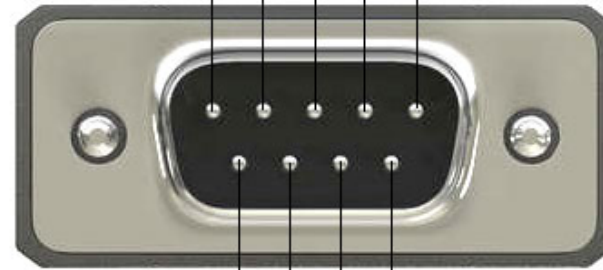

Pin 6: Data Set Ready (DSR)
Pin 7: Request To Send (RTS)
Pin 8: Clear To Send (CTS)
Pin 9: Ring Indicator (RI)





GPIB





馬達

馬達	種類	名稱	
直流馬達	定子的種類	永磁直流馬達	
		線圈式	串激直流馬達
			分激直流馬達
			複激直流馬達
同步馬達	轉子的種類	表面磁鐵式同步馬達	
		內置磁鐵式同步馬達	
		線圈場磁鐵同步馬達	
		同步磁阻馬達	
感應馬達		鼠籠式感應馬達	
		線圈式感應馬達	
無刷馬達		無刷馬達	
	運用其他轉動原理與構造的馬達	步進馬達	
		SR馬達 (切換式磁阻馬達)	
		線性馬達	

步進馬達

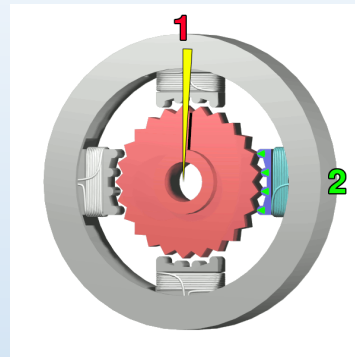

- 步進馬達 (Stepper motor; Step motor) 是直流無刷馬達的一種，為具有如齒輪狀突起（小齒）相契合的定子和轉子，可藉由切換流向定子線圈中的電流，以一定角度逐步轉動的馬達。
- 步進馬達的特徵是採用開迴路控制 (Open-loop control) 處理，不需要運轉量檢知器 (sensor) 或編碼器，且切換電流觸發器的是脈波信號，不需要位置檢出和速度檢出的回授裝置，所以步進馬達可正確地依比例追隨脈波信號而轉動，因此就能達成精確的位置和速度控制，且穩定性佳。



步進馬達種類

2相步進馬達

．．．一般基本步進角爲『 1.8° 』

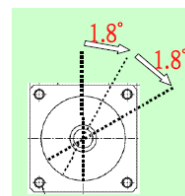

3相步進馬達

．．．一般基本步進角爲『 1.2° 』

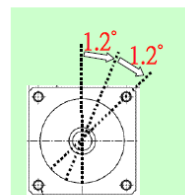

5相步進馬達

．．．一般基本步進角爲『 0.72° 』

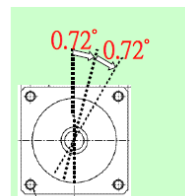

步進馬達內部構造

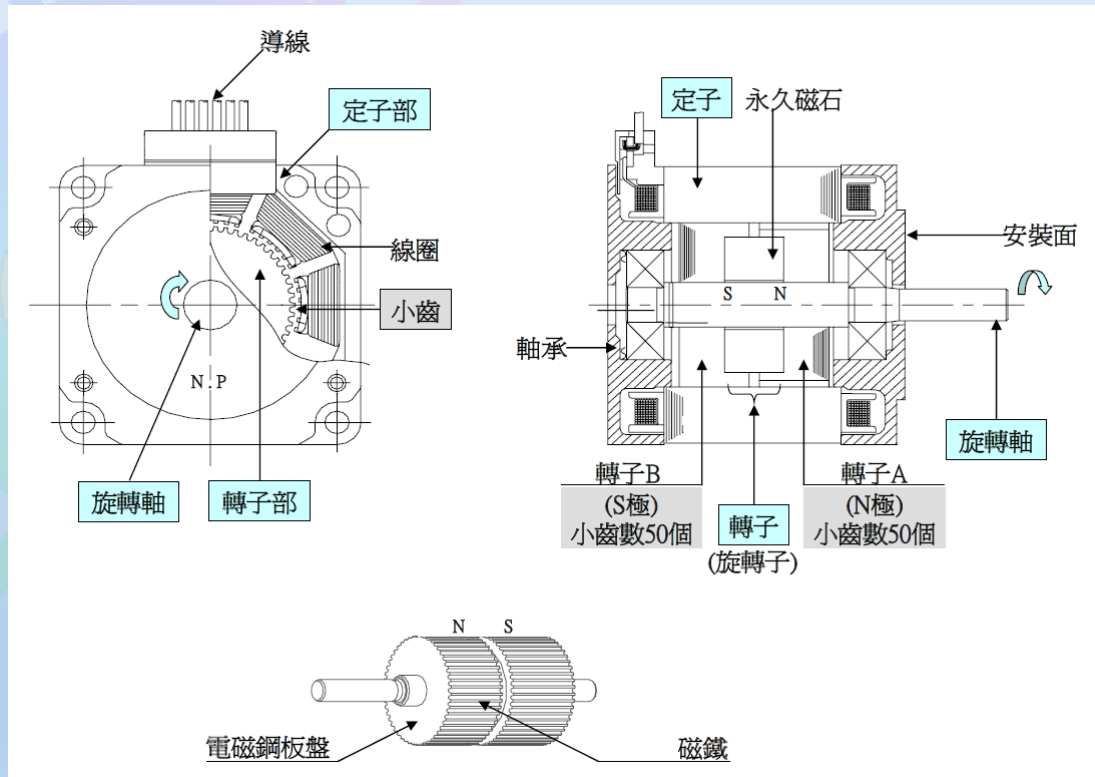



步進馬達內部線圈形式

2相 步進馬達

單極/雙極接線

定子由 2組線圈構成

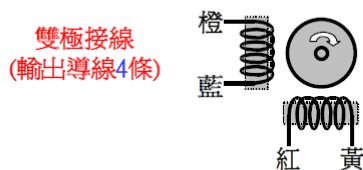
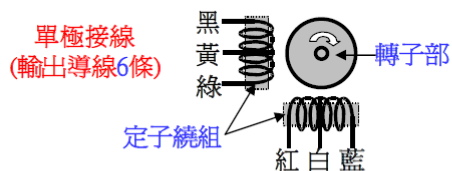

3相 步進馬達

星形接線

定子由 3組線圈構成

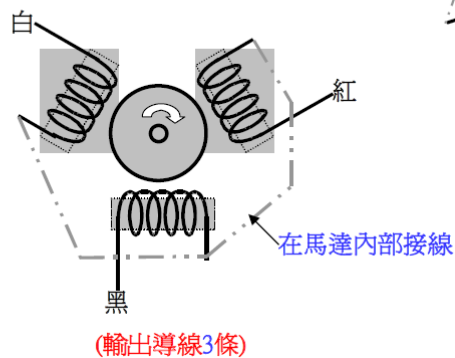

5相 步進馬達

新五角形接線

定子由 5組線圈構成

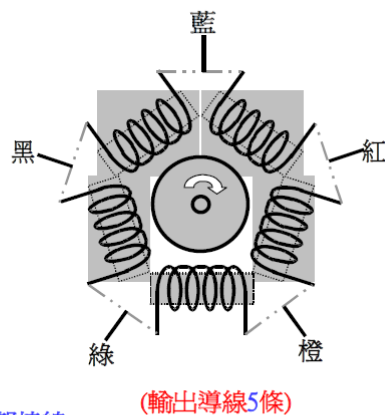



步進馬達動作原理

◎步驟一. 向馬達的線圈通電流

(注意：僅通電流時，馬達並不會運轉)

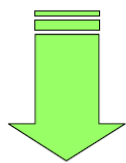

※ 向線圈通電流稱作『**激磁**』

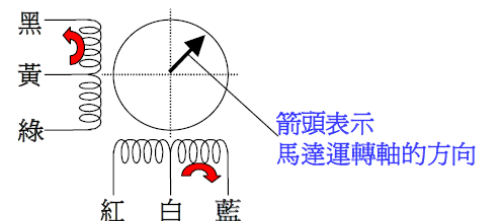

◎步驟二. 切換線圈通電的順序

(注意：僅切換順序但不通電流時，馬達也不會運轉)

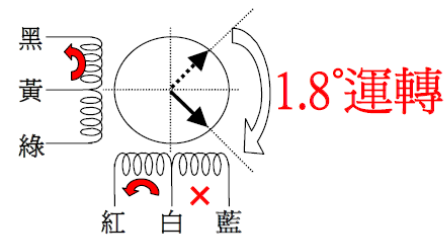
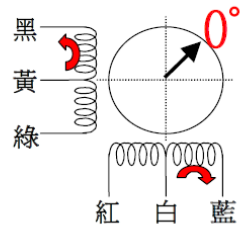

步進馬達激磁方式

◎全步進驅動 (1分割)

.....讓馬達以每個基本步進角進行運轉的方式

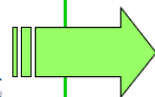

◎半步進驅動 (2分割)

.....讓馬達以每1/2個基本步進角進行運轉的方式

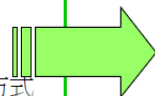

◎微步進驅動 (N分割)

.....讓馬達以每1/N個基本步進角進行運轉的方式
(N=1、2、~)

適用於低速、平滑的運轉

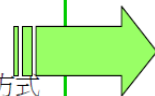

例) 5相步進馬達

基本步進角 0.72° の場合

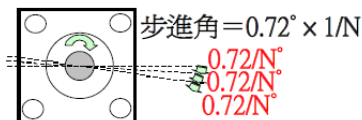
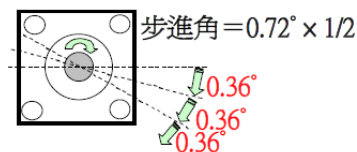
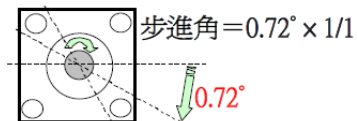



程式設計

- LabVIEW程式操作
- 單晶片微控器Arduino
- LabVIEW+Arduino
- 光束穩定控制、光束特性自動測量、超快雷射脈衝測量與調控





LabVIEW

What is LabVIEW?



LabVIEW(Laboratory Virtual Instrument Engineering Workbench) is a program development application, much like C or BASIC.

However, other programming systems use text-based languages to create lines of code, while LabVIEW uses a graphical programming language, G, to create programs in *block diagram form*.



Block Diagram

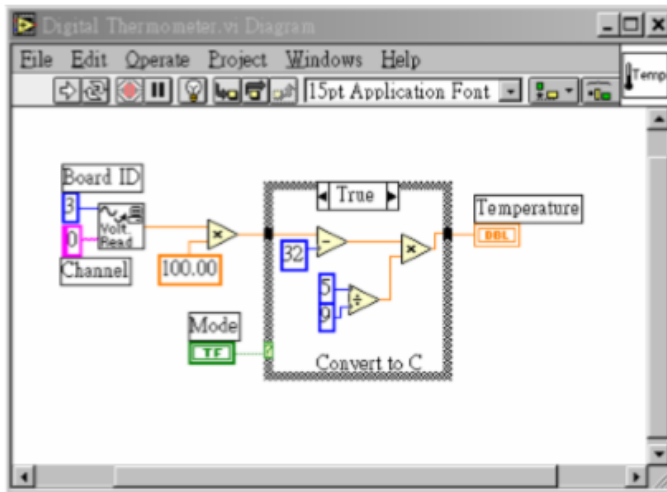

The block diagram contains the graphical source code of your VI (*Virtual Instrument*). In the block diagram, you program your VI to control and perform functions on the inputs and outputs you created on the front panel.

The block diagram can include *functions* and *structures* from the built-in LabVIEW VI libraries. It also can include *terminals* that are associated with controls and indicators created on the front panel.





Front Panel

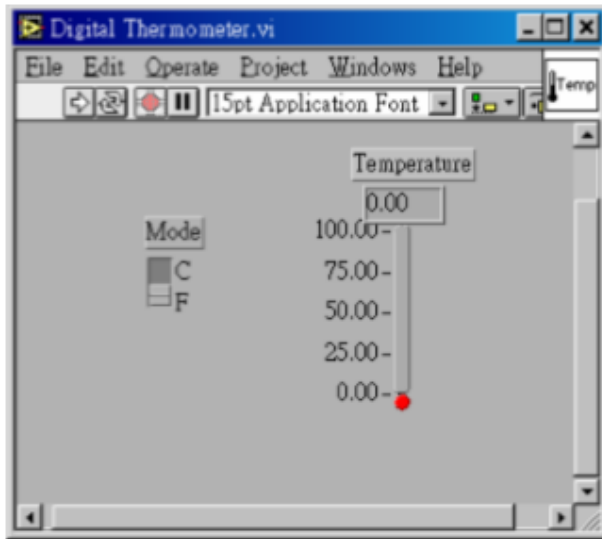

The front panel is the graphical user interface of your LabVIEW VI. This interface collects user input and displays program output. The front panel can contain knobs, push buttons, graphs, and other *controls* and *indicators*.





Front panel demo: a virtual instrument

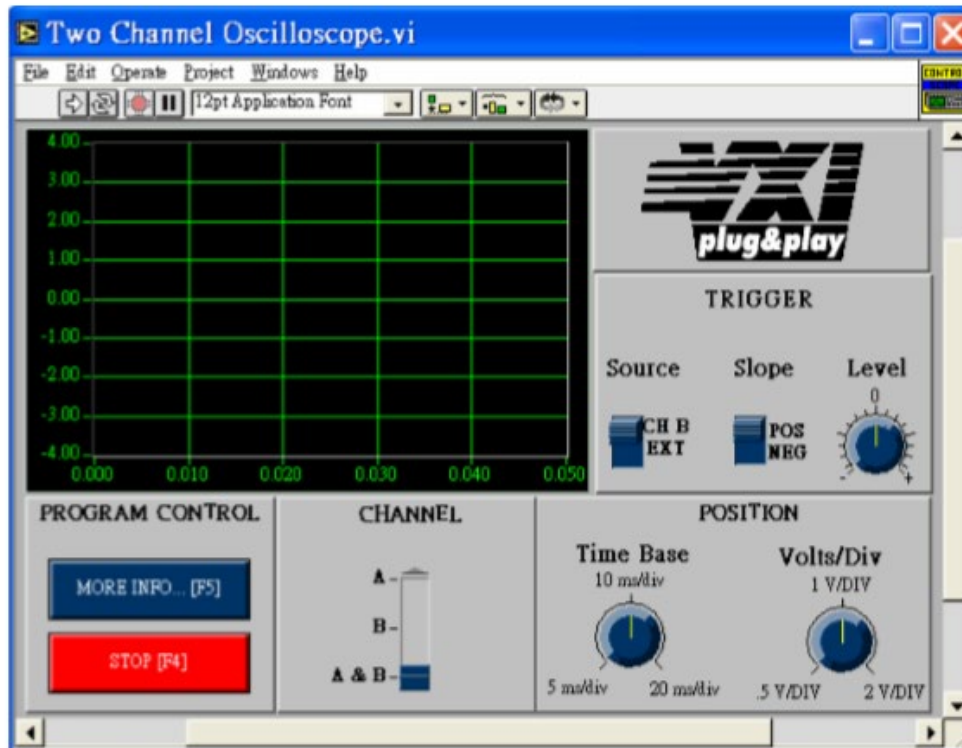



Front panel demo: mixer process control

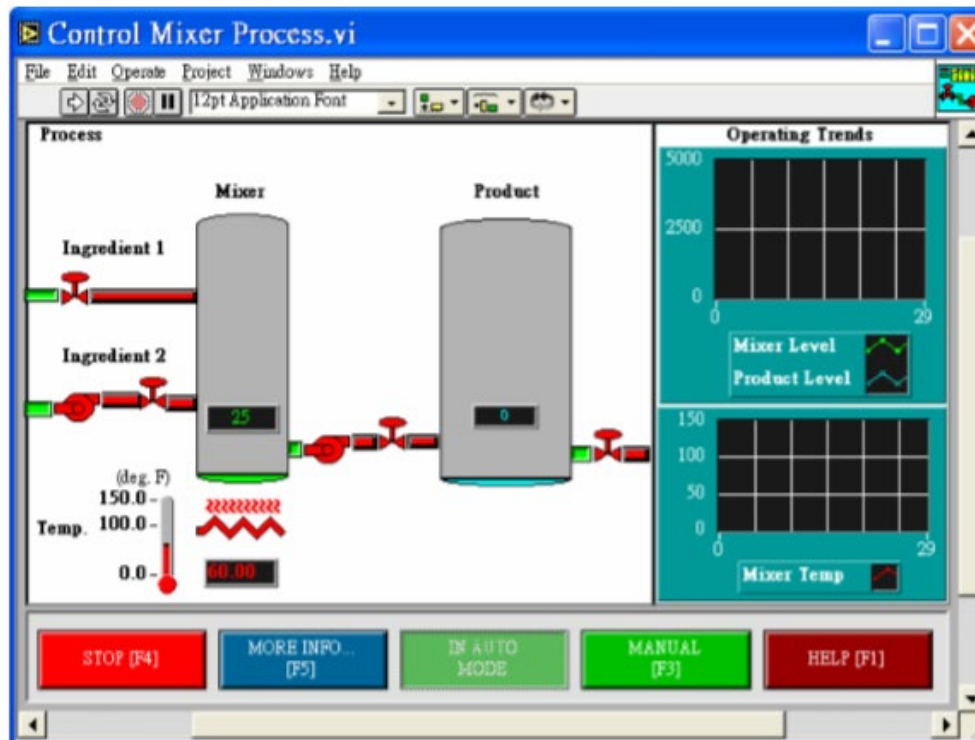



Controls and indicators

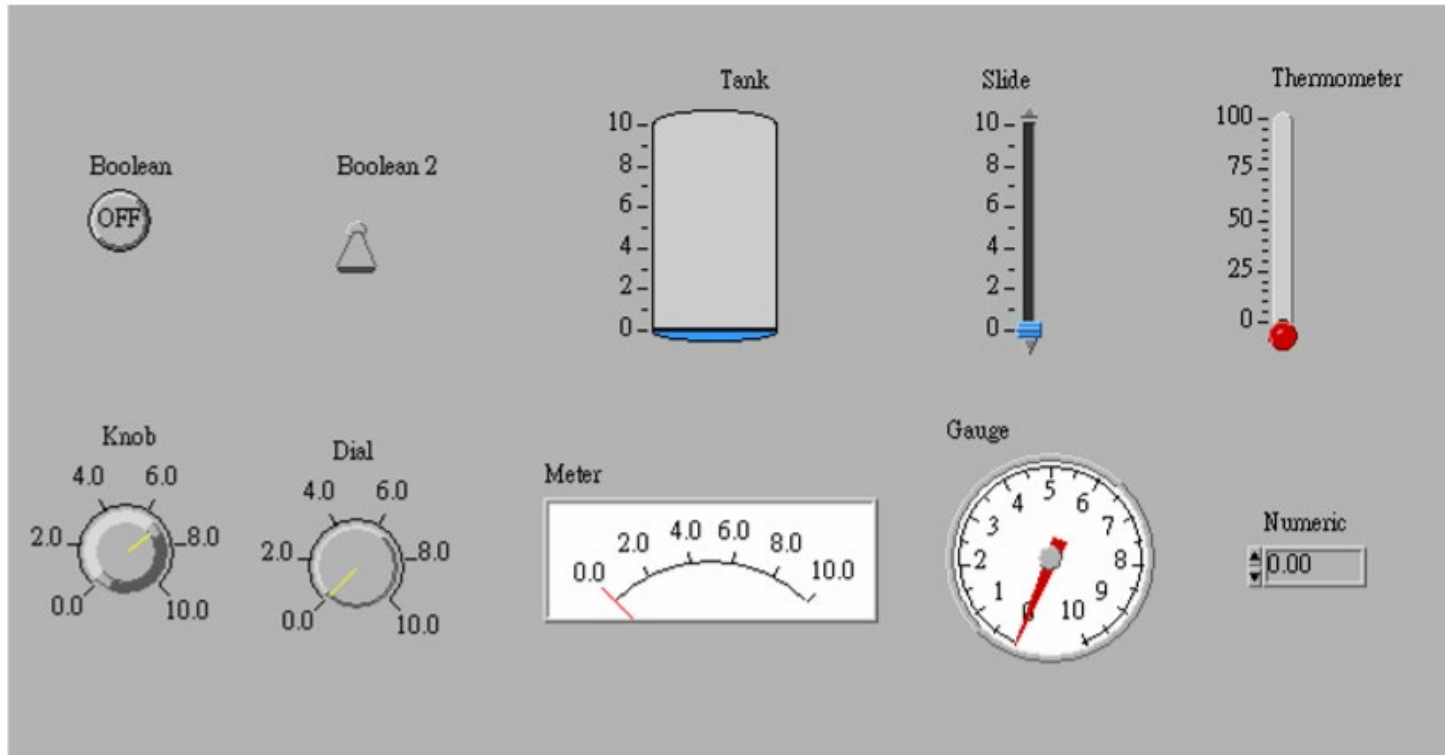



Palettes

LabVIEW *palettes* give you the options you need to create and edit your front panel and block diagram.

Functions Palette



Controls Palette



Tools Palette

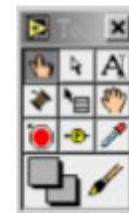

Data Flow

LabVIEW VIs follow a dataflow model for program execution. The block diagram consists of *nodes* such as VIs, structures, and terminals from the front panel. These nodes are connected by *wires*, which define the flow of data through the program. The execution of a node occurs when all its inputs are available. When a node finishes executing, it releases all its outputs to the next node in the dataflow path.

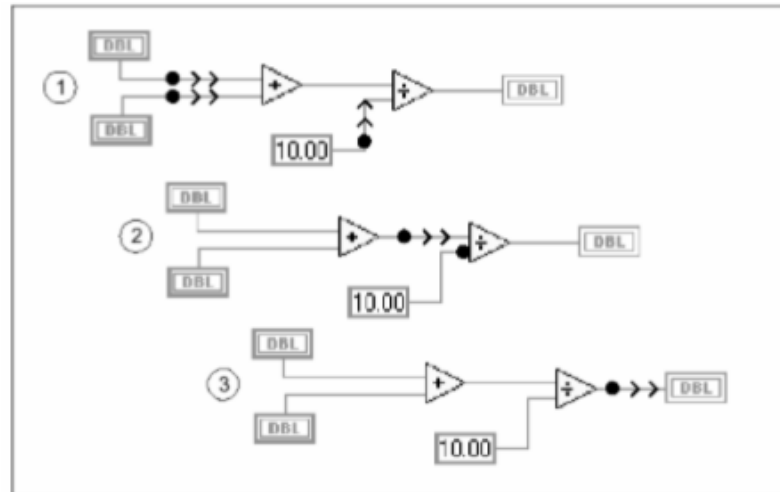



Arithmetic

$$z = \text{sqrt}(\text{abs}(x)) + y;$$

One may use a
formula node:

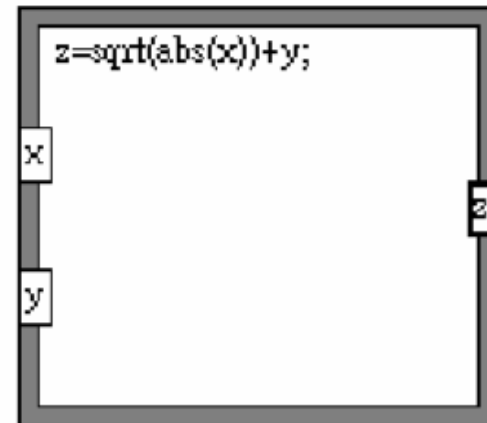
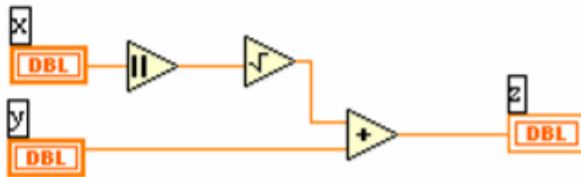



Boolean algebra

$$D = A \text{ AND } (B \text{ OR } C)$$

diagram

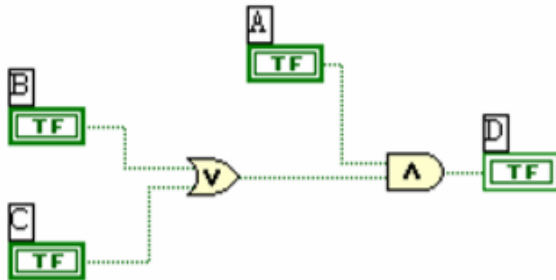

panel

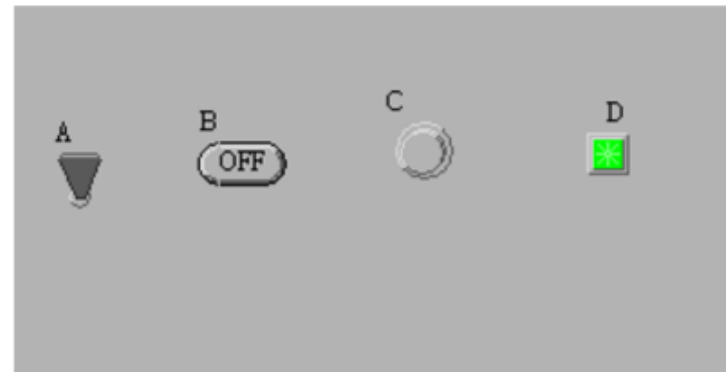



Comparison and CASE structure

```
if a > b then  
    todo list 1.....  
else  
    todo list 2.....  
end
```

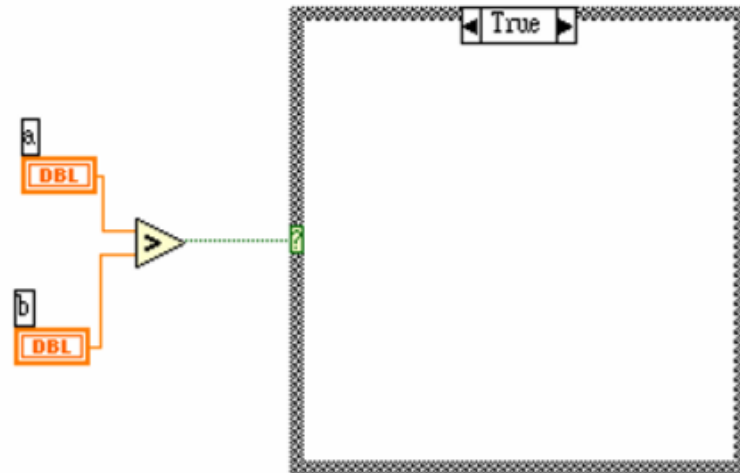



FOR loop

C code:

```
a=1;  
for (i=0, i<6, i++){  
    a=a+a*i;  
}
```

LabVIEW diagram:

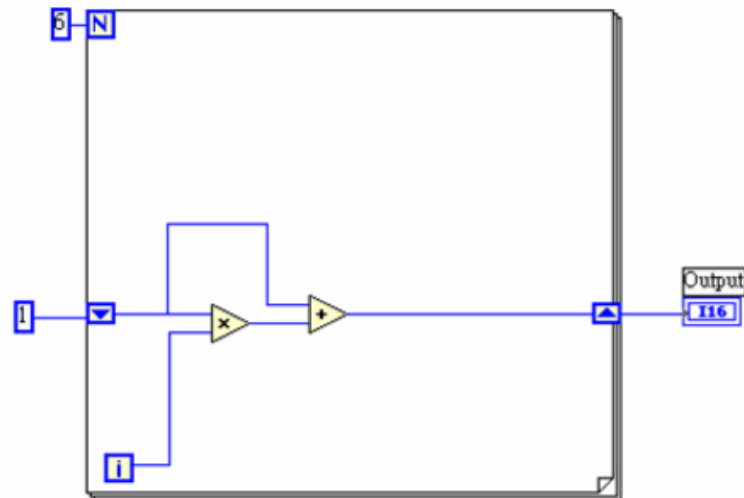



Sequence and while loop

sequence



while loop





Graph and chart

Example: plot a sine wave

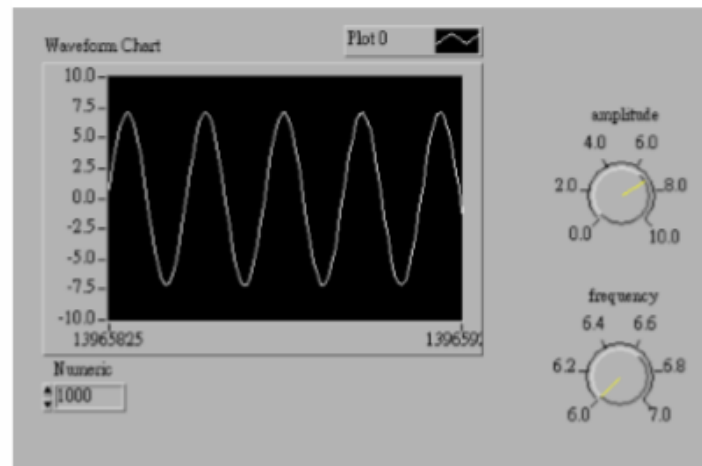
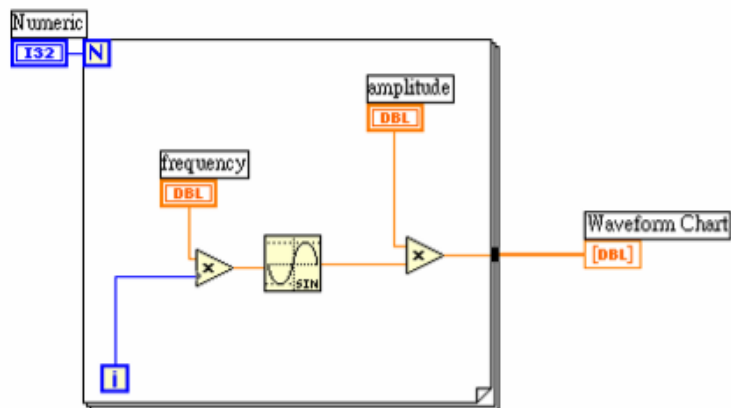



Instrument Control and Data Acquisition: Using LabVIEW

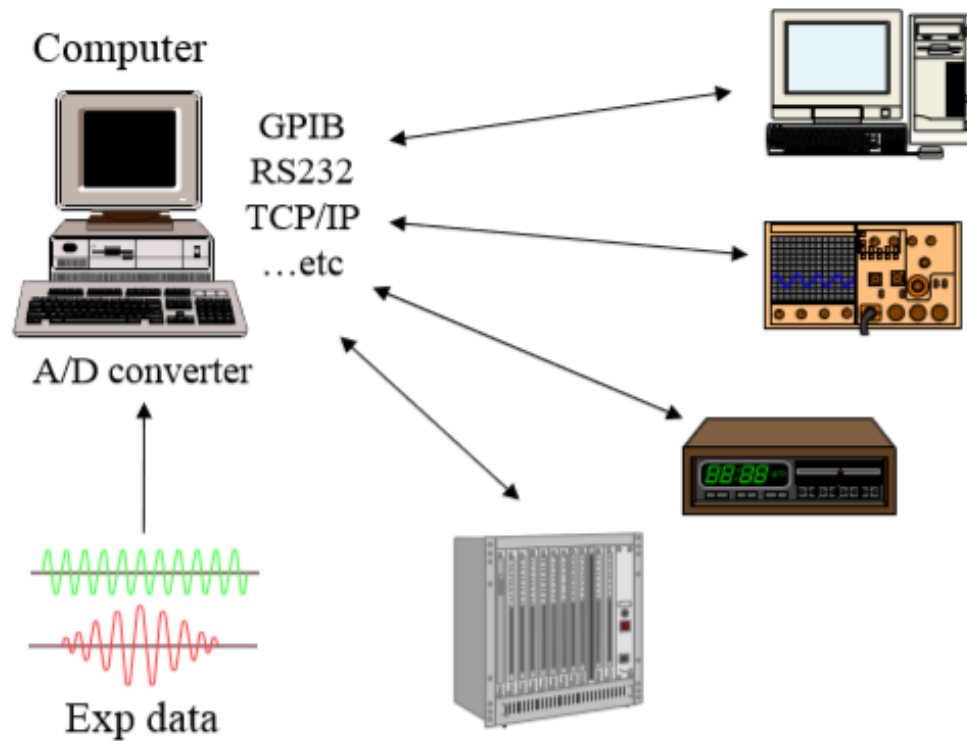



Serial Port VIs

(Functions»Instrument I/O»Serial)

Bytes at Serial Port

Returns in **byte count** the number of bytes in the input buffer of the serial port indicated in **port number**.

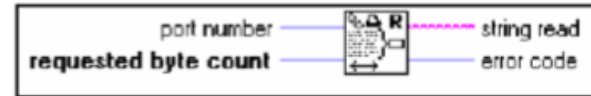

Serial Port Break

Sends a break on the output port specified by **port number** for a period of time at least as long as the **delay** input requests.

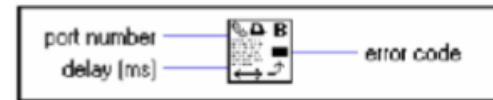

Serial Port Init

Initializes the selected serial port to the specified settings.

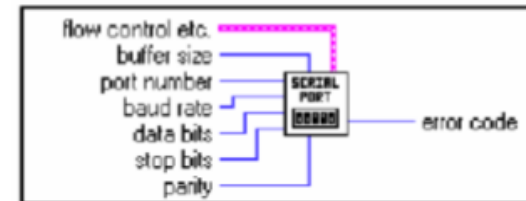



Serial Port VIs (Cont.)

Serial Port Read

Reads the number of characters specified by **requested byte count** from the serial port indicated in **port number**.

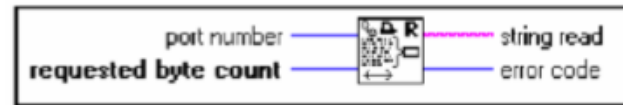

Serial Port Write

LabVIEW Function and VI Reference Manual 36-2 Writes the data in **string to write** to the serial port indicated in **port number**.





Data acquisition basics

- **Signal characteristics**
 - Voltage or current?
 - Amplitude
 - Frequency/ time domain
 - Noise
- **Instrument characteristics**
 - Dynamic range
 - Resolution
 - Frequency response / sampling rate
 - Price





NI MAX

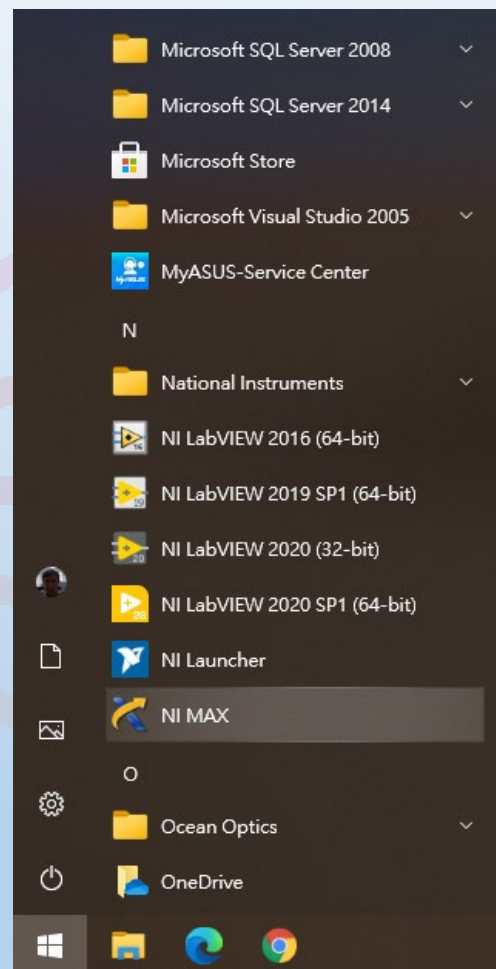



Arduino

- Arduino 簡介
- 二氧化碳感測器簡介
- Arduino 操作示範





單晶片微控制器

- 單晶片，全稱單晶片微電腦，又稱微控制器。是把中央處理器、記憶體、各種輸入輸出介面等都整合在一塊積體電路晶片上的微型電腦。
- 與個人電腦中的微處理器相比，它強調可自給供應並節省成本。最大優點是體積小，可放在儀表內部。但儲存量小，輸入輸出介面簡單。

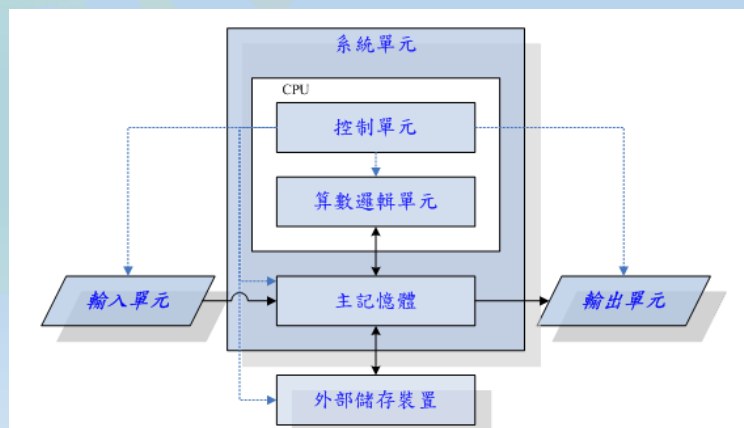



Arduino起源

- 2005年在義大利伊夫雷亞(Ivrea)，由伊夫雷亞互動設計研究所Massimo Banzi和David Cuartielles教授所發展的專案。目的是為學生或互動藝術設計師提供一種低成本且簡單的方法，以建立使用傳感器與環境相互作用的裝置。
- Arduino這個名字來自義大利伊夫雷亞的一家酒吧。酒吧以Arduin命名，他是伊夫雷亞地區伯爵，也是1002年至1014年期間的義大利國王。



Arduino 簡介

- Arduino 是一家製作開源硬體和軟體的公司。該公司設計並製造可用於構建數位裝置和互動式物件的控制板和套件，以便在物理世界中感知和控制物件。
- Arduino 的電路板設計使用了多種微控制器。這些電路板配有一組數位和類比 I/O 接腳，可以連接各種擴充板或麵包板和其他電路。這些電路板具有串列埠，可從個人電腦載入程式。除了使用傳統的編譯工具之外，Arduino 還提供了一個整合式開發環境。



```
Arduino 1.8.5
Arduino IDE
This example code is in the public domain.
http://www.arduino.cc/en/Tutorial/Blink
*/
// the setup function runs once when you press reset or power the board
void setup() {
  // initialize digital pin LED_BUILTIN as an output.
  pinMode(LED_BUILTIN, OUTPUT);
}
// the loop function runs over and over again forever
void loop() {
  digitalWrite(LED_BUILTIN, HIGH); // turn the LED on (HIGH is the voltage level)
  delay(1000); // wait for a second
  digitalWrite(LED_BUILTIN, LOW); // turn the LED off by making the voltage LOW
  delay(1000); // wait for a second
}
```





Arduino 簡介



- Arduino 是使用開放原始碼的軟硬體平台，它提供了簡單好用的I/O介面，並可使用類似於Java、C語言等高階語言的開發環境。
- 開放源碼(open-source)：軟體的開發環境可在網上免費下載，在硬體上Arduino 的電路設計圖也可從官方網站下載，依據自身之需求進行修改，但須要符合創用CC授權條款。
- Arduino開發簡單，參考資料多。不需要電子電機相關科系的背景，也可以很容易學會Arduino相關互動裝置的開發。由於 Arduino 以公開共享為基礎，有時只需要參考分享者的作品，依據自身的需求進行調整，就可以在短時間內完成自己的創作。



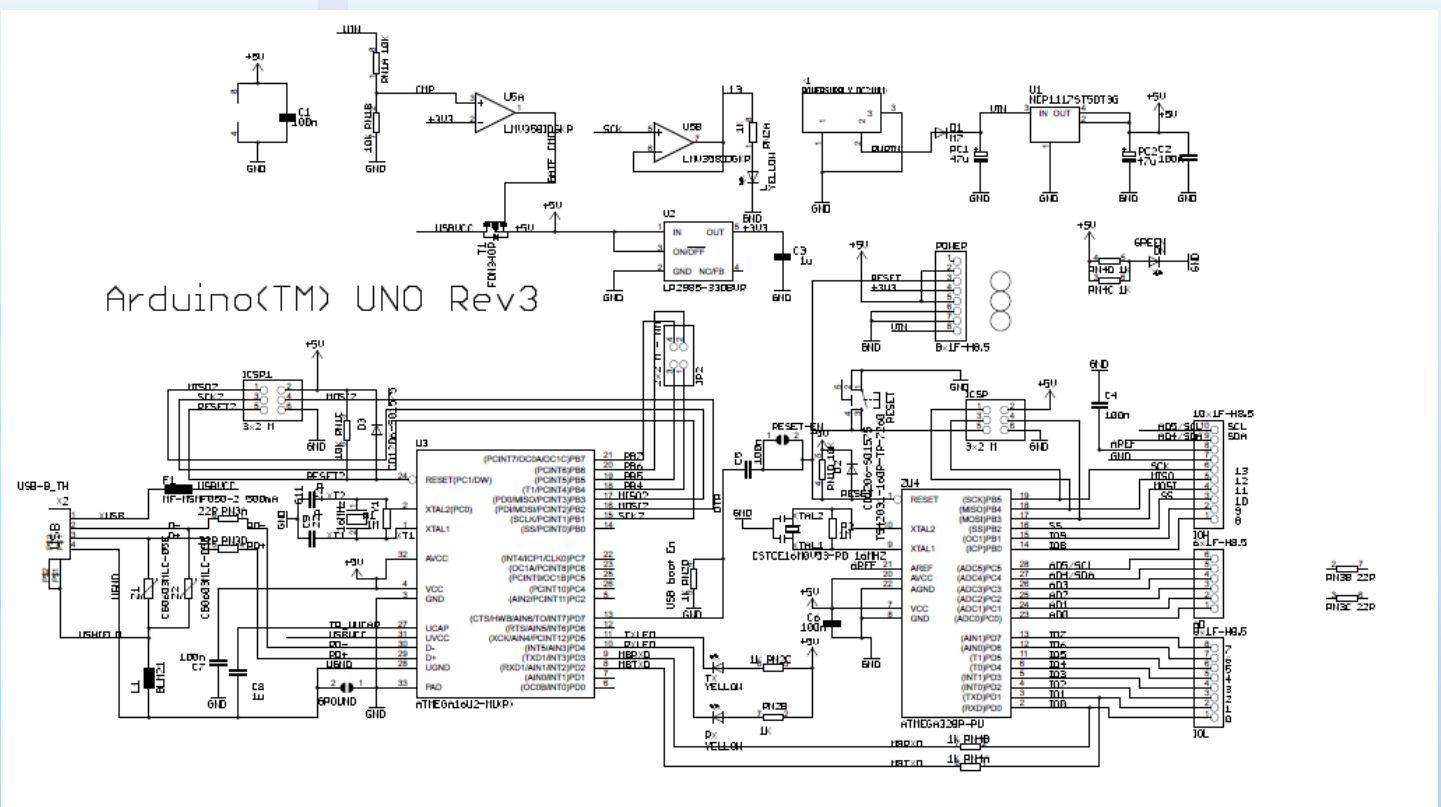

Reference Designs ARE PROVIDED "AS IS" AND "WITH ALL FAULTS. Arduino DISCLAIMS ALL OTHER WARRANTIES, EXPRESS OR IMPLIED, REGARDING PRODUCTS, INCLUDING BUT NOT LIMITED TO, ANY IMPLIED WARRANTIES OF MERCHANTABILITY OR FITNESS FOR A PARTICULAR PURPOSE. Arduino may make changes to specifications and product descriptions at any time, without notice. The Customer must not rely on the absence or characteristics of any features or instructions marked "reserved" or "undefined." Arduino reserves these for future definition and shall have no responsibility whatsoever for conflicts or incompatibilities arising from future changes to them. The product information on the Web Site or Materials is subject to change without notice. Do not finalize a design with this information. ARDUINO is a registered trademark. Use of the ARDUINO name must be compliant with <http://www.arduino.cc/en/Main/Policy>





各式Arduino控制板

The screenshot shows the Arduino website's 'Entry Level' product page. The browser address bar displays 'https://www.arduino.cc/en/Main/Products'. The navigation menu includes 'HOME', 'STORE', 'SOFTWARE', 'EDU', 'RESOURCES', 'COMMUNITY', and 'HELP'. On the left, a sidebar lists categories: 'Summary', 'Entry Level', 'Enhanced Features', 'IoT', 'Education', 'Wearable', and 'Retired'. The main content area features the heading 'Entry Level' and a paragraph: 'Get started with Arduino using Entry Level products: easy to use and ready to power your first creative projects. These boards and modules are the best to start learning and tinkering with electronics and coding. The StarterKit includes a book with 15 tutorials that will walk you through the basics up to complex projects.' Below this text, six Arduino boards are displayed in a 2x3 grid, each with a label: 'ARDUINO UNO', 'ARDUINO LEONARDO', 'ARDUINO 101', 'ARDUINO ESPLORA', 'ARDUINO MICRO', and 'ARDUINO NANO'.





Arduino控制板功能簡介

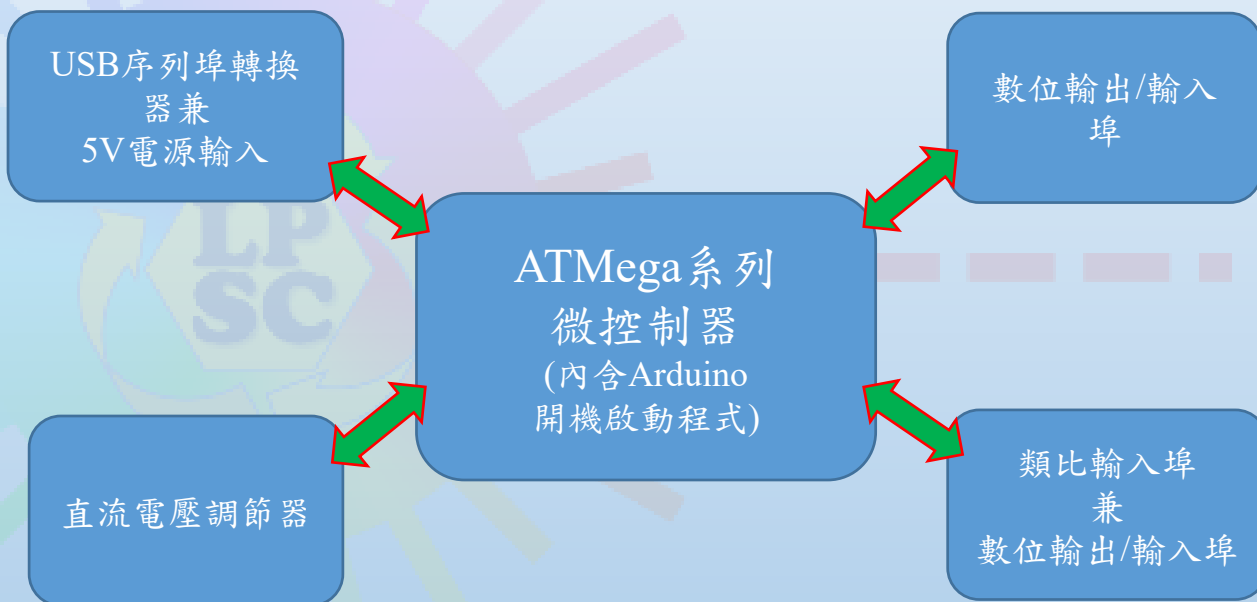

Arduino UNO R3

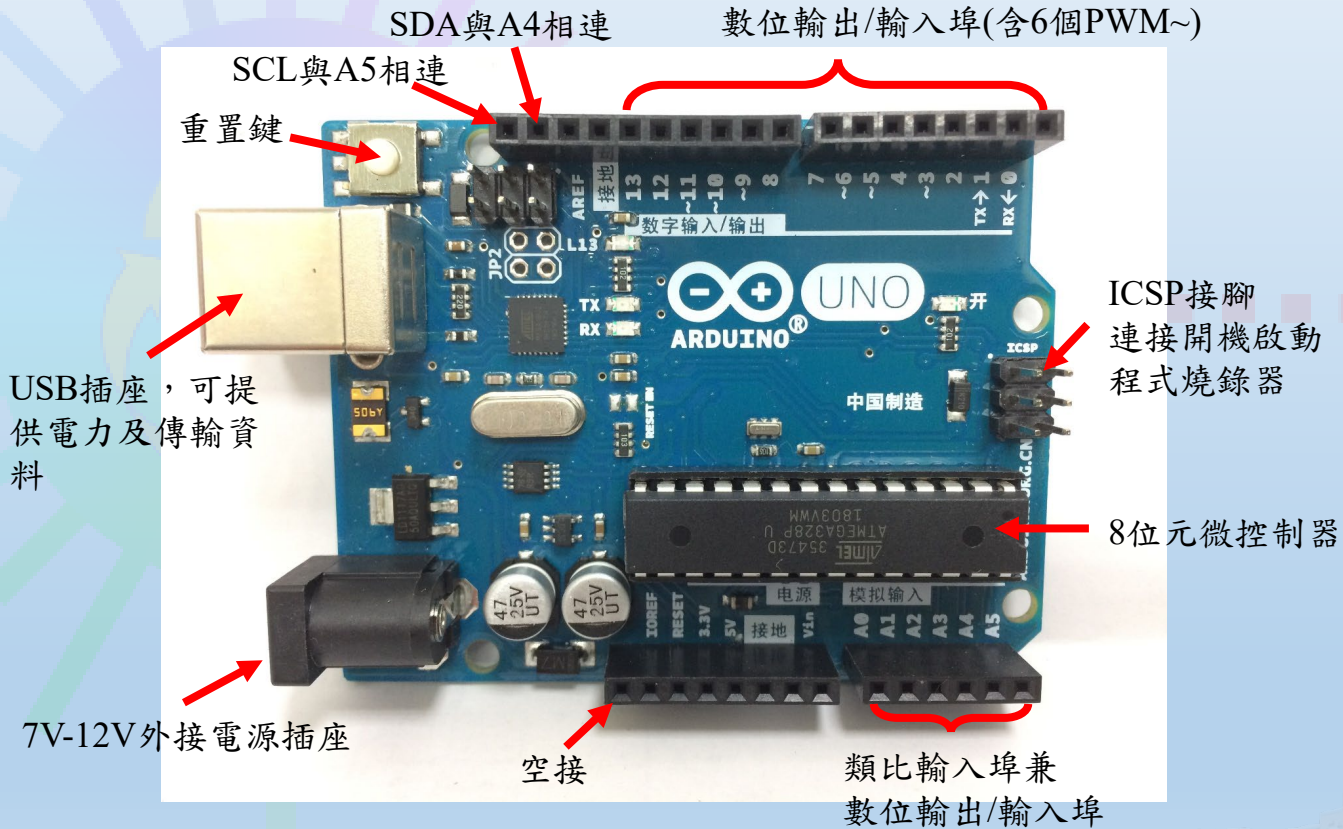



Arduino硬體介紹

- Reset：當Reset腳為Low時，微控制器會重置。
- 類比輸入接腳：6支類比輸入腳，標記為A0到A5，每支腳都可提供10位元的解析(即1024種不同的數值)。這些腳位所用的參考電壓預設為0到5V，不過參考電壓可以更改，方法是透過AREF腳和analogReference()函式一起使用。
- I²C：A4(SDA)和A5(SCL)這兩支腳。透過Wire Library可以提供I²C通訊。
- 數位I/O接腳：14支數位I/O接腳可以當作輸入或輸出使用。使用方法是透過pinMode()，digitalWrite()，與digitalRead()這幾個函式。





Arduino硬體介紹

- 序列通訊：0(RX)和1(TX)這兩支腳。用來接收(RX)與傳輸(TX)TTL訊號的序列資料。這兩支腳也連接到USB Converter晶片中。
- 外部中斷：2和3這兩支腳。搭配attachInterrupt()函式可以利用外部事件觸發中斷。
- PWM：3, 5, 6, 10和11共六支腳。透過analogWrite()函式可以提供8-bit的PWM輸出。
- SPI：10(SS)，11(MOSI)，12(MISO)和13(SCLK)這四支腳。搭配SPI Library可提供SPI序列通訊。
- LED：13。內建一顆LED，當pin腳為High時，LED亮，當pin腳為Low時，LED暗。



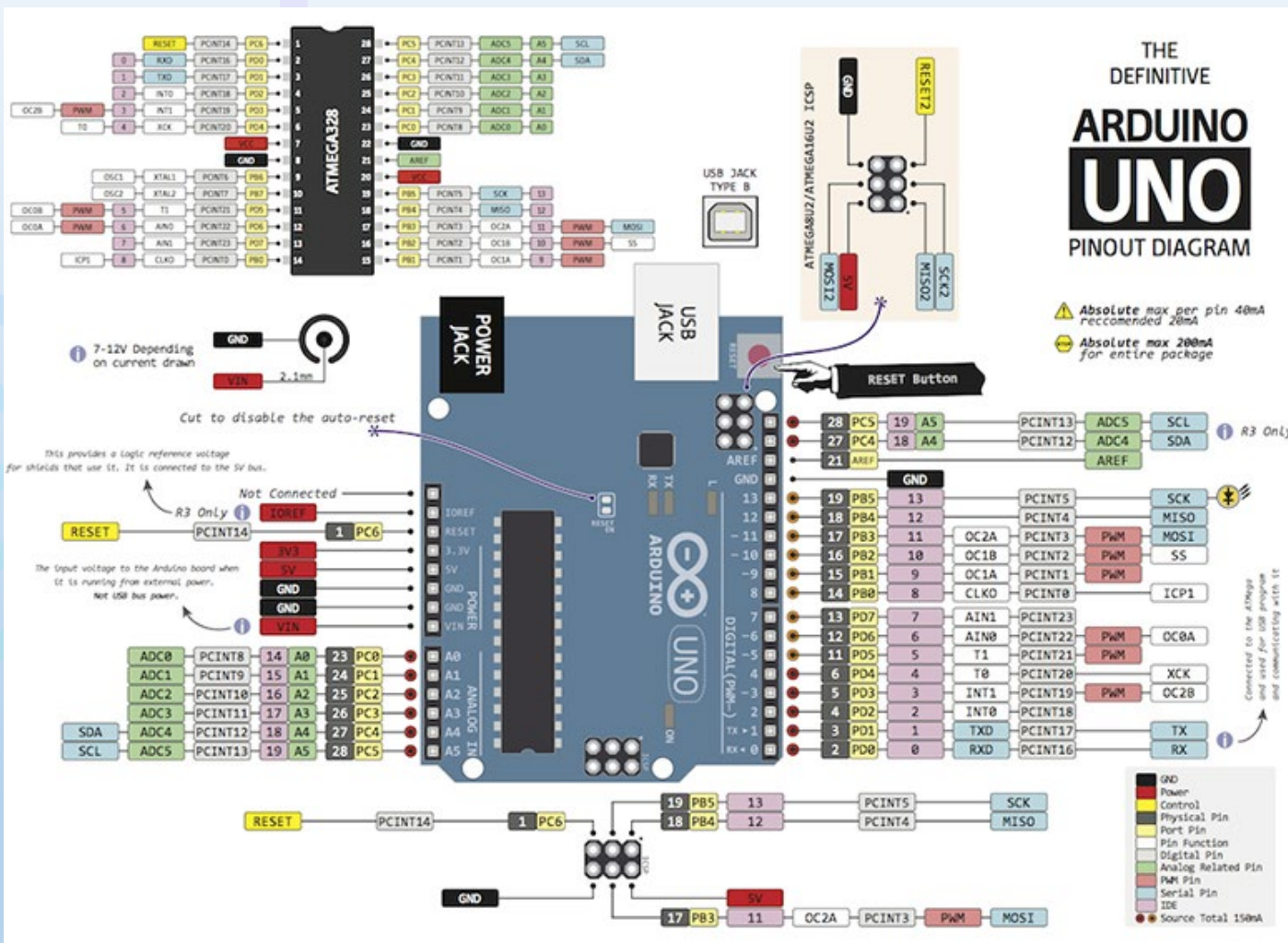



單晶片 ATMEGA328P-PU 規格

商品屬性	屬性值
製造商	Microchip (Atmel)
產品類型	8位元微控制器
系列	ATmega328P
核心	AVR
數據匯流排寬度	8 bit
最高時鐘頻率	20 MHz
程序內存大小	32 kB
程序存儲器類型	Flash
數據存儲器大小	2 kB
數據存儲器類型	SRAM
數據記憶體大小	1 kB
數據記憶體類型	EEPROM
工作電源電壓	1.8 V to 5.5 V
輸入/輸出數	23 I/O
ADC解析度	10 bit





ATMEGA328P-PU結構與功能

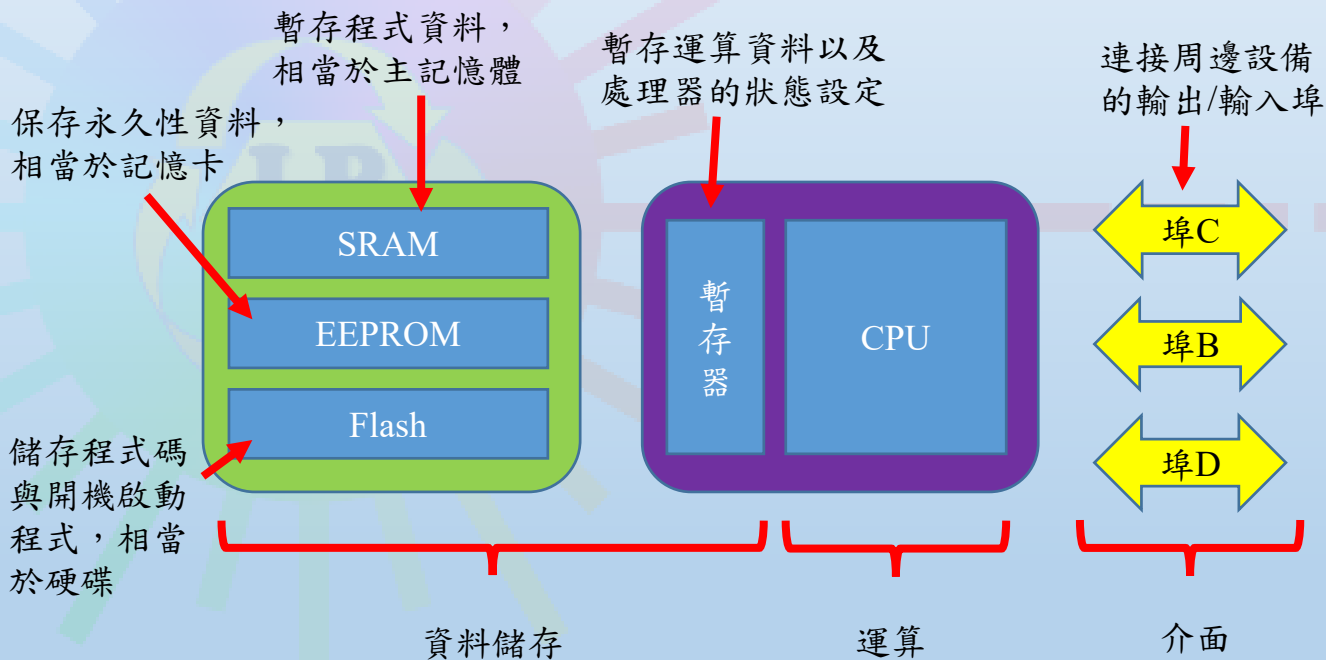



Arduino 軟體介紹

- 軟體開發所需要的開發環境、編譯器、連結器、開發工具鏈、燒錄程式、板子與電腦連接所需要的驅動程式等等，這些通通都已經準備妥當並打包好了，可以到Arduino官方網站的 [下載頁面](http://arduino.cc/en/Main/Software) <http://arduino.cc/en/Main/Software> 即可下載。程式可在Windows、Mac OS X、Linux上運行。
- Arduino 的軟體整合開發環境(IDE)是開放源碼。具備主功能表、常用工具列、程式編輯介面及訊息顯示視窗。它所用的程式語言語法類似於 C/C++。運用這個開發工具可進行程式的上傳，及各項感應器的溝通。





Arduino 軟體介紹







- 使用 Arduino IDE 編寫的程式被稱為草稿碼 (Sketch)。這些草稿碼都以程式編輯器來編輯。預設草稿碼的名稱就是檔案名稱。常用工具列提供了驗證、上傳、新增、開啟及儲存等功能。而序列埠監控視窗則可監視 Arduino I/O 數值。

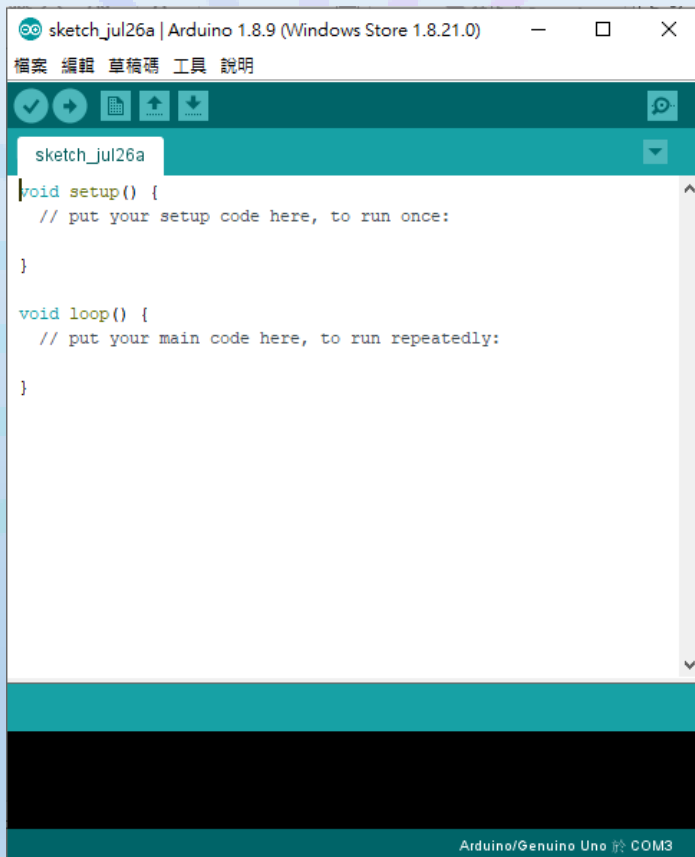



Arduino開發環境的介面



-  驗證
檢查參數設定或引入程式是否產生錯誤。
-  上傳
程式編譯完成，將程式碼透過USB介面燒錄至Arduino控制板。
-  新增
產生新的草稿碼
-  開啟
開啟舊的草稿碼。
-  儲存
草稿碼儲存。
-  序列埠監控視窗
開啟監視器頁面，監視Arduino I/O介面。





Arduino程式組成

- Arduino 程式主要由 setup() 和 loop() 這兩個函式組成：
- 因為 setup() 和 loop() 是每個 Arduino 程式都會用到的兩個函式。為了方便，Arduino 已經幫大家準備好程式基本架構了。例如，編寫 Arduino 程式時，可直接點選 檔案 > 範例 > 01.Basics > Blink 這個範例檔，另存新檔後，然後再修改 setup() 和 loop() 兩個函式的內容即可。





二氧化碳偵測





MG811 二氧化碳感測器模組

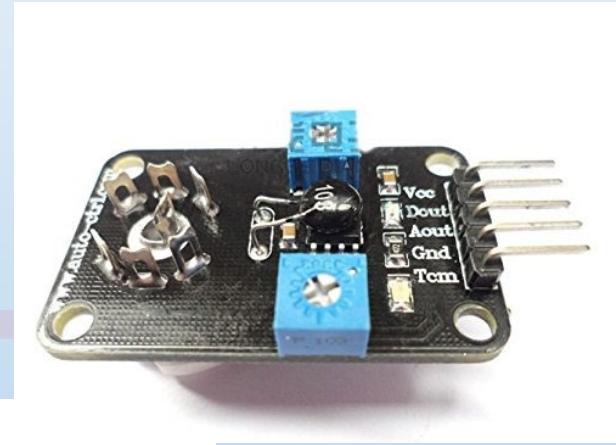



二氧化碳感測器模組說明

- 一、尺寸：32mm X22mm X30mm長*寬*高
- 二、主要芯片：LM393、二氧化碳氣體感應探頭
- 三、工作電壓：直流6V。
- 四、特點：
 - 1、具有信號輸出指示；
 - 2、雙路信號輸出（類比輸出及TTL電壓輸出）；
 - 3、TTL輸出有效信號為低電壓。（當輸出低電壓時信號燈亮，可直接接單片機）
 - 4、類比輸出(0-2V/0-4V)兩種電壓輸出可選，預設為0-2V；
 - 5、對二氧化碳具有很高的靈敏度和良好的選擇性；
 - 6、具有長期的使用壽命和可靠的穩定性；
 - 7、快速的響應恢復特性；
 - 8、探頭可以插拔設計，方便試驗。
- 五、應用：

用於家庭、環境的二氧化碳探測裝置。適宜於二氧化碳濃度的探測。二氧化碳氣體敏感元件測試濃度範圍：0 to 10000ppm
- 注意：使用MG811感測器，**Arduino開發板必須外接供電(7.5V-9v)**，否則**量測數據不準確**。此外範例僅針對放大器的部分做預設宣告，如果您需要得比較精準的CO₂濃度PPM數據，仍須在實驗室環境下有精準的測試空間與環境下進行校正。校準時需通入定量的氣體，調整信號放大電位器校準輸出
- 第一次使用最好預熱24小時，相隔六小時以上使用，需預熱1-2小時，斷電72小時以上，預熱24小時



二氧化碳感測器模組說明

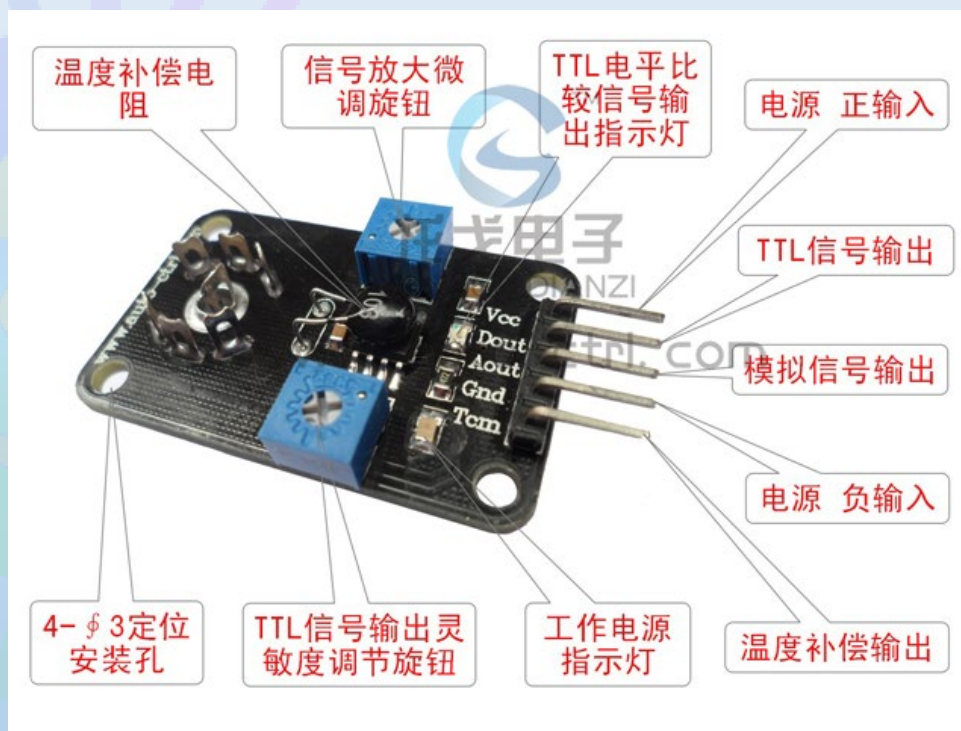

感測器模組 http://www.logoele.com/products_detail/productId=98.html



MG811探測頭特性曲線

- 目前市面上中低價位用來偵測CO₂氣體的模組，採用的多是MG811探測頭。利用固體電解質電池原理透過空氣中的CO₂與其產生電極反應造成電位差來反應CO₂的濃度，優點是便宜且誤差不會太大，能偵測400~10000ppm濃度範圍的CO₂。

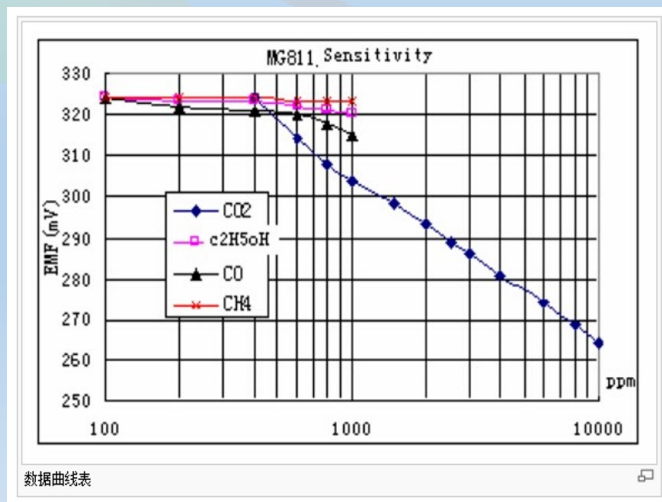

数据曲线表



MG811 二氧化碳探測頭

- 特點

- 對CO₂有良好的靈敏度和選擇性
- 受溫溼度的變化影響較小
- 良好的穩定性、再現性

- 應用

- 空氣品質控制系統
- 發酵過程控制
- 溫室CO₂濃度檢測



MG811 結構及測試電路

• 感測器組成

1. 固態電解質層
2. 金電極
3. 鉑引線
4. 加熱器
5. 陶瓷管
6. 100目雙層不銹鋼網
7. 鍍鎳銅卡環
8. 膠木基座
9. 針狀鍍鎳銅管腳

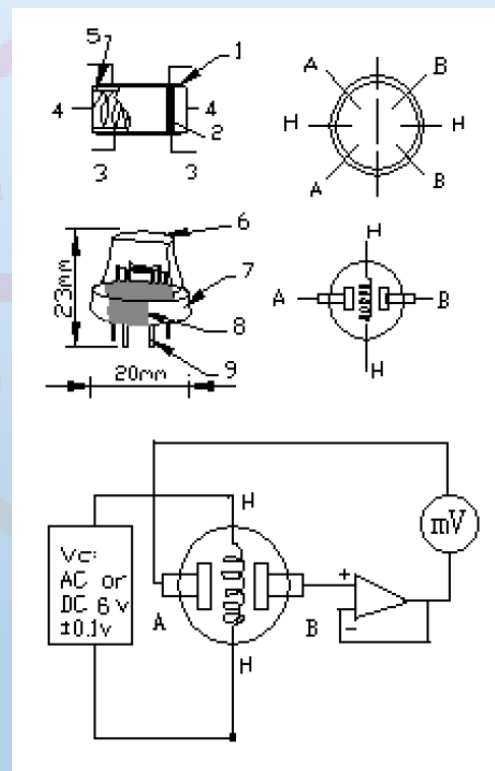



二氧化碳感測模組電路

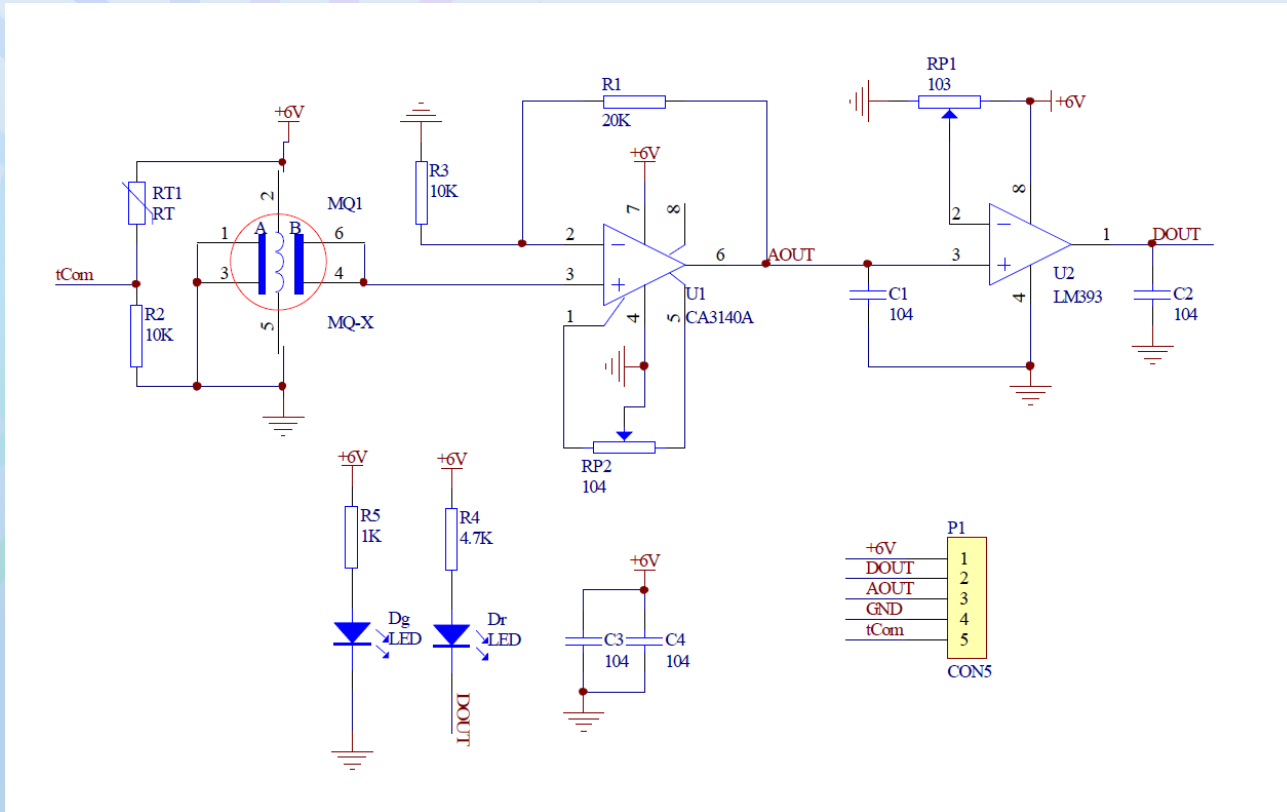



MG811工作原理

- 感測器採用固態電解質電池原理

- 空氣，Au|NASICON||碳酸鹽|Au，空氣，CO₂

- 電極反應

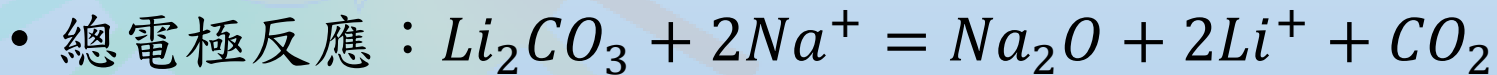
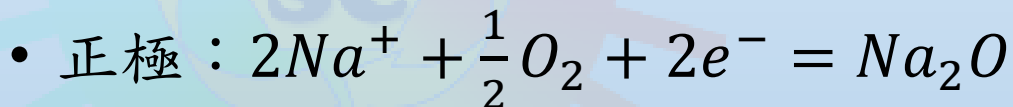
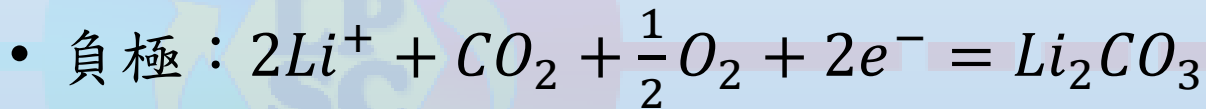

NASICON: sodium (Na) Super Ionic CONductor





MG811工作原理

- 感測器電極間之電位差(EMF)符合能斯特方程：

- $$EMF = E_c - \frac{RT}{2F} \ln(P(CO_2))$$

- $P(CO_2)$ ： CO_2 分壓
- E_c ：常數
- R ：氣體常數
- T ：絕對溫度(K)
- F ：法拉第常數

- 感測元件加熱電壓由外電路提供，當其表面溫度足夠高時，元件相當於一個電池。兩端會輸出電壓信號，其值與能斯特方程符合得很好。元件測量時放大器的阻抗須在100-1000 $G\Omega$ 之間，其測試電流應控制在1 pA以下。





Arduino 二氧化碳感測器組裝

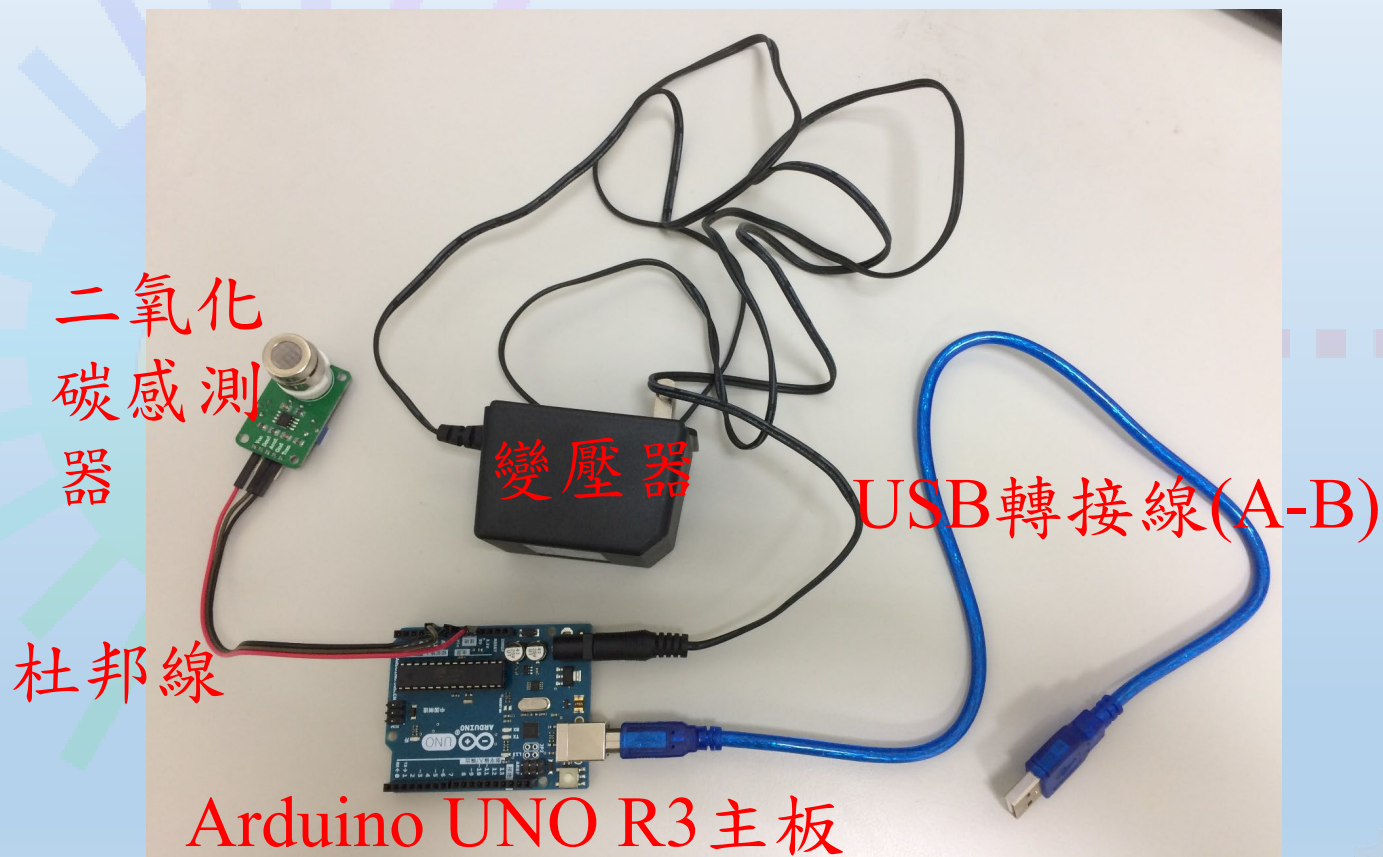

杜邦線接法

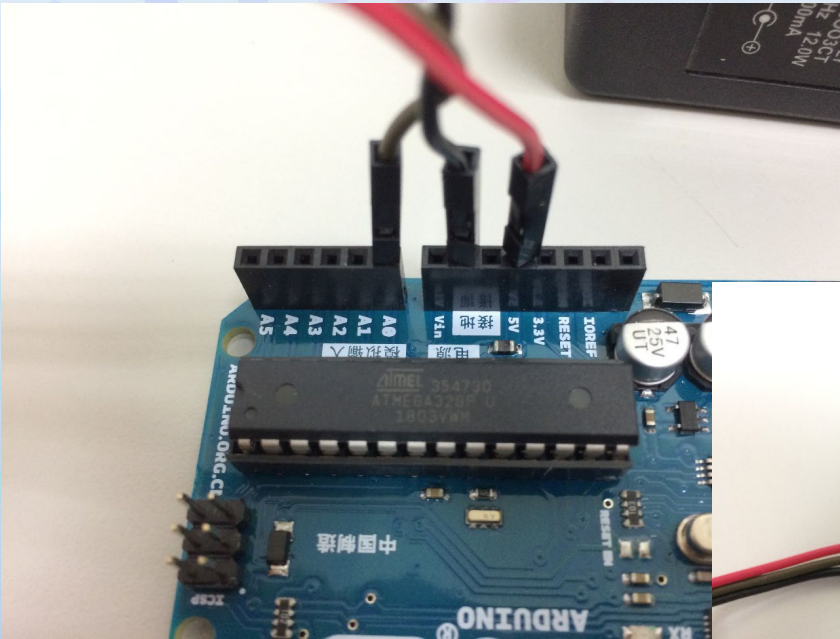



Arduino 軟體下載安裝

- <https://www.arduino.cc/> Arduino 官方

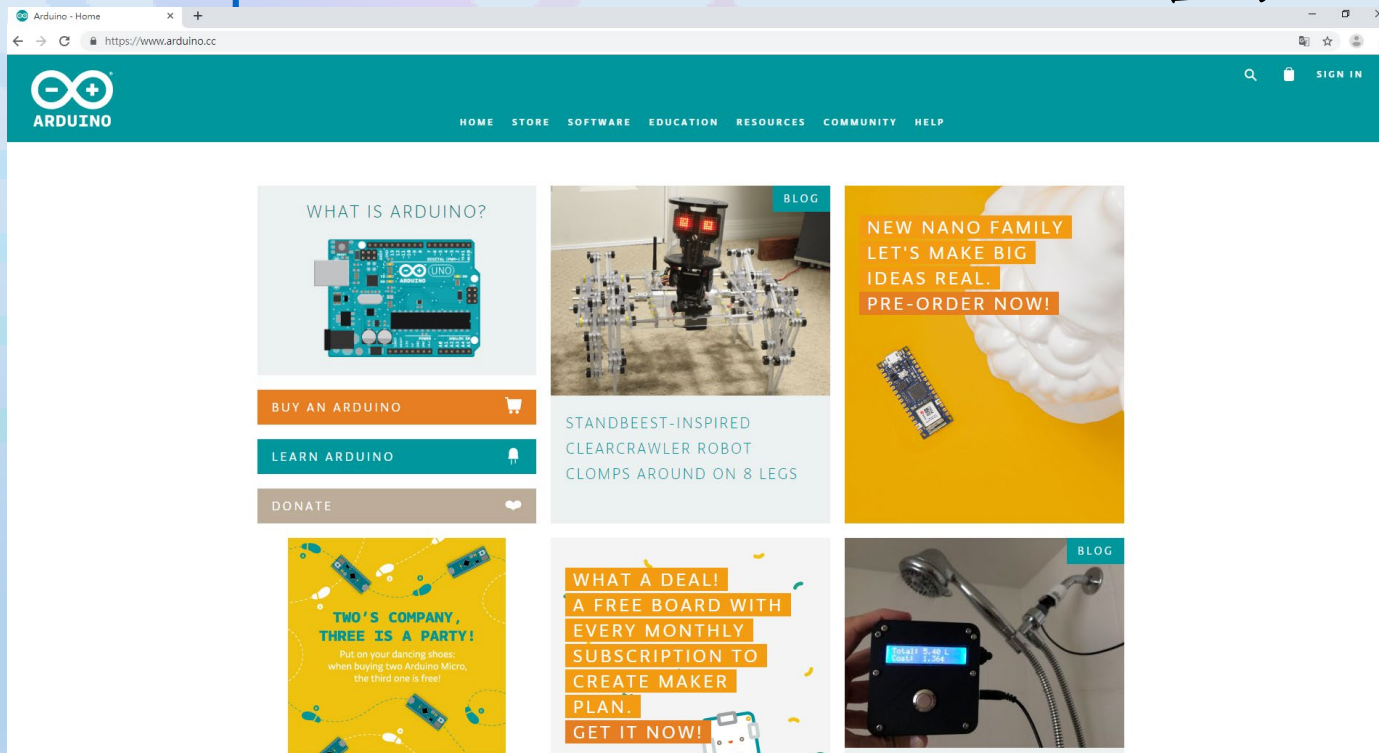



Software → Downloads

The screenshot shows the Arduino website homepage. The browser address bar displays "https://www.arduino.cc". The navigation menu includes "HOME", "STORE", "SOFTWARE", "EDUCATION", "RESOURCES", "COMMUNITY", and "HELP". A sub-menu is open under "SOFTWARE", showing "ONLINE TOOLS" and "DOWNLOADS".

Key content cards on the page include:

- WHAT IS ARDUINO?**: A card featuring an image of an Arduino Uno board with buttons for "BUY AN ARDUINO", "LEARN ARDUINO", and "DONATE".
- STANDBEEST-INSPIRED CLEARCRAWLER ROBOT**: A card with a photo of a robot and the text "CLOMPs AROUND ON 8 LEGS".
- NEW NANO FAMILY**: A card with a yellow background, a photo of a Nano board, and the text "LET'S MAKE BIG IDEAS REAL. PRE-ORDER NOW!".
- TWO'S COMPANY, THREE IS A PARTY!**: A promotional card for Arduino Micro boards.
- WHAT A DEAL!**: A card for a subscription service with the text "A FREE BOARD WITH EVERY MONTHLY SUBSCRIPTION TO CREATE MAKER PLAN. GET IT NOW!".
- SHOWER MONITOR HELPS YOU**: A card with a photo of a shower monitor device.





選擇 Windows 安裝版本

The screenshot shows the Arduino Software website with the following content:

- Navigation:** HOME, STORE, SOFTWARE, EDU, RESOURCES, COMMUNITY, HELP
- Banner:** GET HOOKED ON THESE DEALS! 20% OFF SELECTED ARDUINO PRODUCTS.
- Section: Download the Arduino IDE**
 - ARDUINO 1.8.9**
 - The open-source Arduino Software (IDE) makes it easy to write code and upload it to the board. It runs on Windows, Mac OS X, and Linux. The environment is written in Java and based on Processing and other open-source software.
 - This software can be used with any Arduino board. Refer to the Getting Started page for installation instructions.
 - Windows** Installer, for Windows XP and up
Windows ZIP file for non admin install
 - Windows app** Requires Win 8.1 or 10
[Get](#)
 - Mac OS X** 10.8 Mountain Lion or newer
 - Linux 32 bits
 - Linux 64 bits
 - Linux ARM 32 bits
 - Linux ARM 64 bits
 - [Release Notes](#)
 - [Source Code](#)
 - [Checksums \(sha512\)](#)
- HOURLY BUILDS**
 - Download a **preview of the incoming release** with the most updated features and bugfixes.
 - Windows
 - Mac OS X (Mac OS X Mountain Lion or later)
 - Linux 32 bit, Linux 64 bit, Linux ARM, Linux ARM64
- BETA BUILDS**
 - Download the **Beta Version** of the Arduino IDE with experimental features. This version should NOT be used in production.
 - Windows
 - Mac OS X (Mac OS X Mountain Lion or later)
 - Linux 32 bit, Linux 64 bit, Linux ARM, Linux ARM64





Just Download or...

The screenshot shows the Arduino website's donation page. At the top, there is a teal navigation bar with the Arduino logo and menu items: HOME, STORE, SOFTWARE, EDUCATION, RESOURCES, COMMUNITY, and HELP. The main heading is "Contribute to the Arduino Software". Below this, a paragraph explains that contributions support development and are not tax deductible. A central graphic features three stylized characters (a board, a chip, and a brain) and text stating that the Arduino IDE has been downloaded 34,097,730 times since March 2015. Below the text are five circular buttons for donation amounts: \$3, \$5, \$10, \$25, and \$50, plus an "OTHER" button. At the bottom, there are two buttons: "JUST DOWNLOAD" and "CONTRIBUTE & DOWNLOAD". The browser's address bar shows the URL https://www.arduino.cc/en/Main/Donate.

Arduino - Donate

https://www.arduino.cc/en/Main/Donate

ARDUINO

HOME STORE SOFTWARE EDUCATION RESOURCES COMMUNITY HELP

Contribute to the Arduino Software

Consider supporting the Arduino Software by contributing to its development. (US tax payers, please note this contribution is not tax deductible). Learn more on how your contribution will be used.

SINCE MARCH 2015, THE ARDUINO IDE HAS BEEN DOWNLOADED **34,097,730** TIMES. (IMPRESSIVE!) NO LONGER JUST FOR ARDUINO AND GENUINO BOARDS, HUNDREDS OF COMPANIES AROUND THE WORLD ARE USING THE IDE TO PROGRAM THEIR DEVICES, INCLUDING COMPATIBLES, CLONES, AND EVEN COUNTERFEITS. HELP ACCELERATE ITS DEVELOPMENT WITH A SMALL CONTRIBUTION! REMEMBER: OPEN SOURCE IS LOVE!

\$3 \$5 \$10 \$25 \$50 OTHER

JUST DOWNLOAD CONTRIBUTE & DOWNLOAD





安裝檔版本/壓縮檔版本

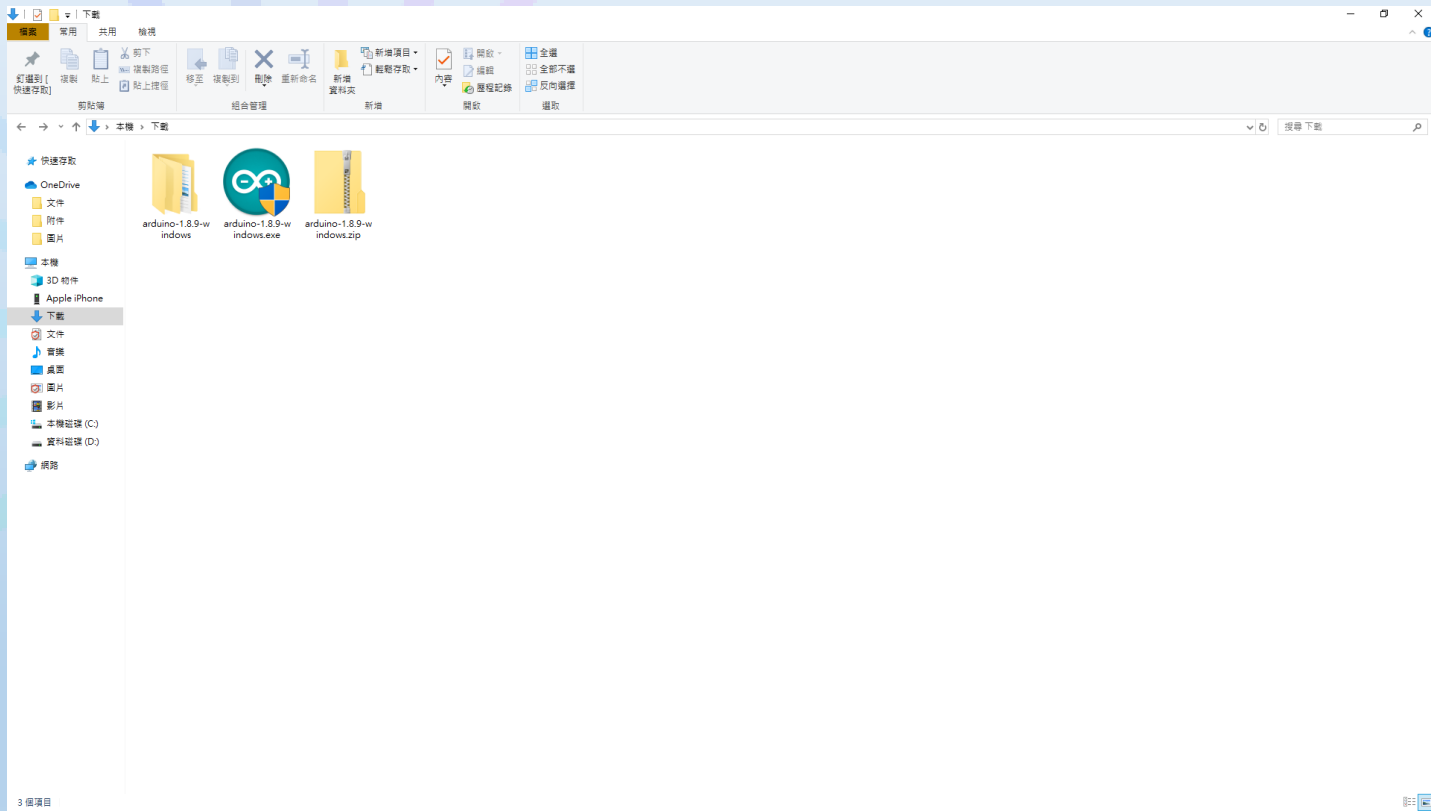



Windows 8.1 or 10

The screenshot shows the Microsoft Store page for Arduino IDE. The page is in Chinese and includes the following elements:

- Header:** Microsoft Store navigation bar with search, cart, and login options.
- Product Card:**
 - Image:** Arduino IDE logo (a blue circle with a white infinity symbol).
 - Title:** Arduino IDE
 - Developer:** Arduino LLC • 开发人员工具
 - Rating:** 5 stars, 12 reviews
 - Description:** Arduino is an open-source electronics platform based on easy-to-use hardware and software. It's intended for anyone making interactive projects.
 - Important Note:** IMPORTANT: This app performs with core functionality on Windows 10 S but some limited plugins do not work. We are working with Microsoft on a fix.
 - Price:** 免費 (Free)
 - Buttons:** 取得 (Get) and 查看系統需求 (View system requirements)
- Navigation:** 概觀 (Overview), 系統需求 (System requirements), 評論 (Reviews), 相關 (Related)
- 適用平台 (Compatible platforms):** 電腦 (PC)
- 描述 (Description):** Same as the product card description.
- 螢幕擷取畫面 (Screenshots):** Three small screenshots showing the IDE interface.
- Taskbar:** Shows two open files: arduino-1.8.9-win...zip and arduino-1.8.9-wi...exe.





執行 Arduino IDE

目前開啟的檔名

主功能表

程式編輯視窗

訊息窗格

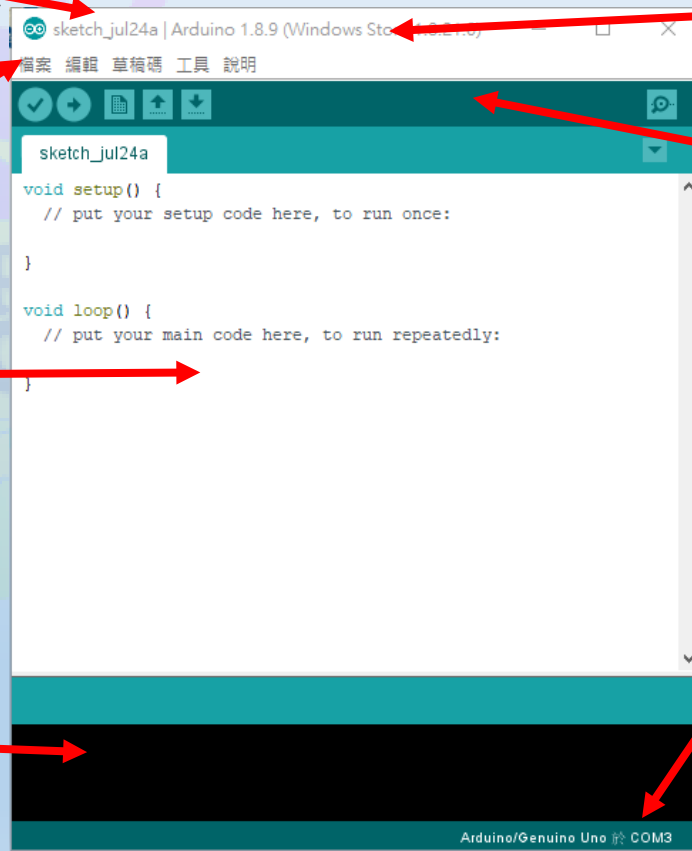

Arduino編輯器版本

工具列

Arduino控制板名稱及通訊埠編號





開啟檔案...驗證...上傳

```
ReadCO2 | Arduino 1.8.9 (Windows Store 1.8.21.0)
檔案 編輯 草稿碼 工具 說明
ReadCO2
#include "CO2Sensor.h"

CO2Sensor co2Sensor(A0, 0.99, 100);

void setup() {
  Serial.begin(9600);
  Serial.println("=== Initialized ===");
  co2Sensor.calibrate();
}

void loop() {
  int val = co2Sensor.read();
  Serial.print("CO2 value: ");
  Serial.println(val);

  delay(1000);
}
```

Arduino/Genuino Uno 於 COM3

I. 開啟範例程式

Blink

調整閃爍頻率

II. 二氧化碳偵測

將CO2Sensor資料夾Copy到
Arduino/libraries資料夾內

開啟CO2Sensor/examples/ReadCO2
內的ReadCO2.ino





開啟序列埠監控視窗

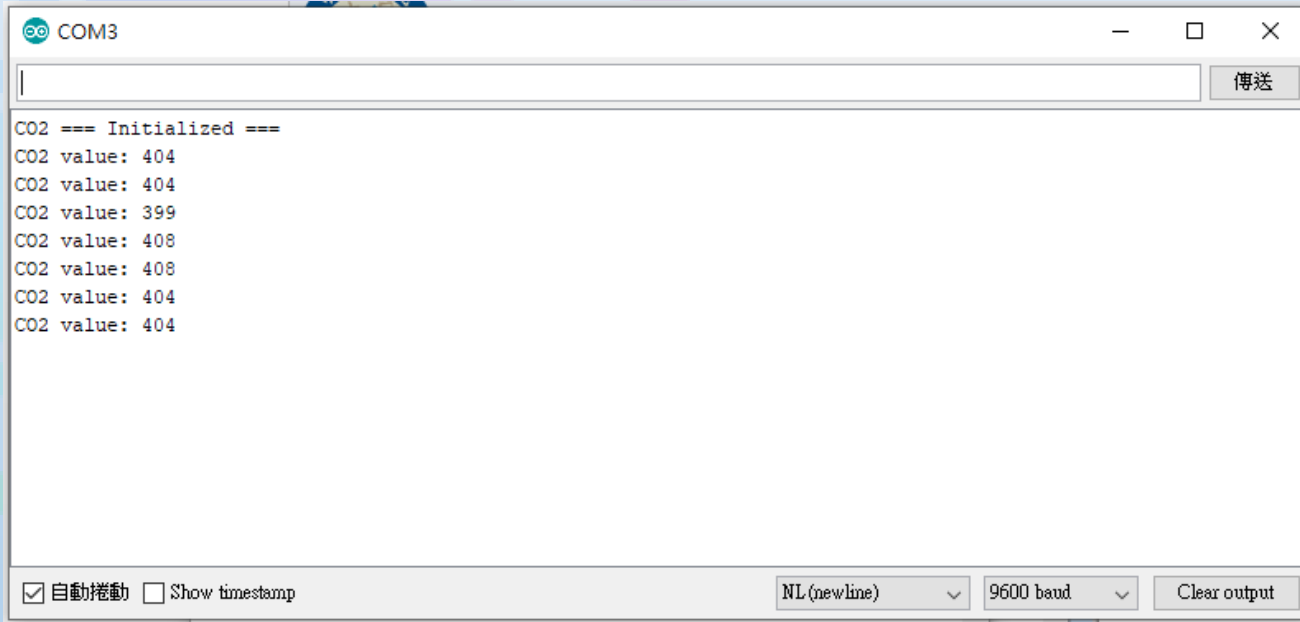



實驗量測與訊號處理

- 物理訊號→電子訊號→擷取與數位化→儲存→分析處理
 - 影像、光譜、質譜、電性、磁性、聲、光、溫度、壓力、能量、作用力、形變、傳輸運動、酸鹼、氧化還原、離子.....
 - 各種偵測器的特性(如何提供偏壓、飽和、噪音、阻抗)和應用
 - 訊號擷取與數位化、同步觸發、負載與失真、雜訊控制、阻抗匹配.....。
 - 數據分析與數據繪圖軟體





資料儲存 - TeraTerm

- TeraTerm 下載網址：<http://ttssh2.osdn.jp/>
- 安裝設定
- 連接Arduino控制板後，開啟TeraTerm程式
- 讀取的資料自動接續存放於teraterm.log檔案中



感測器校正

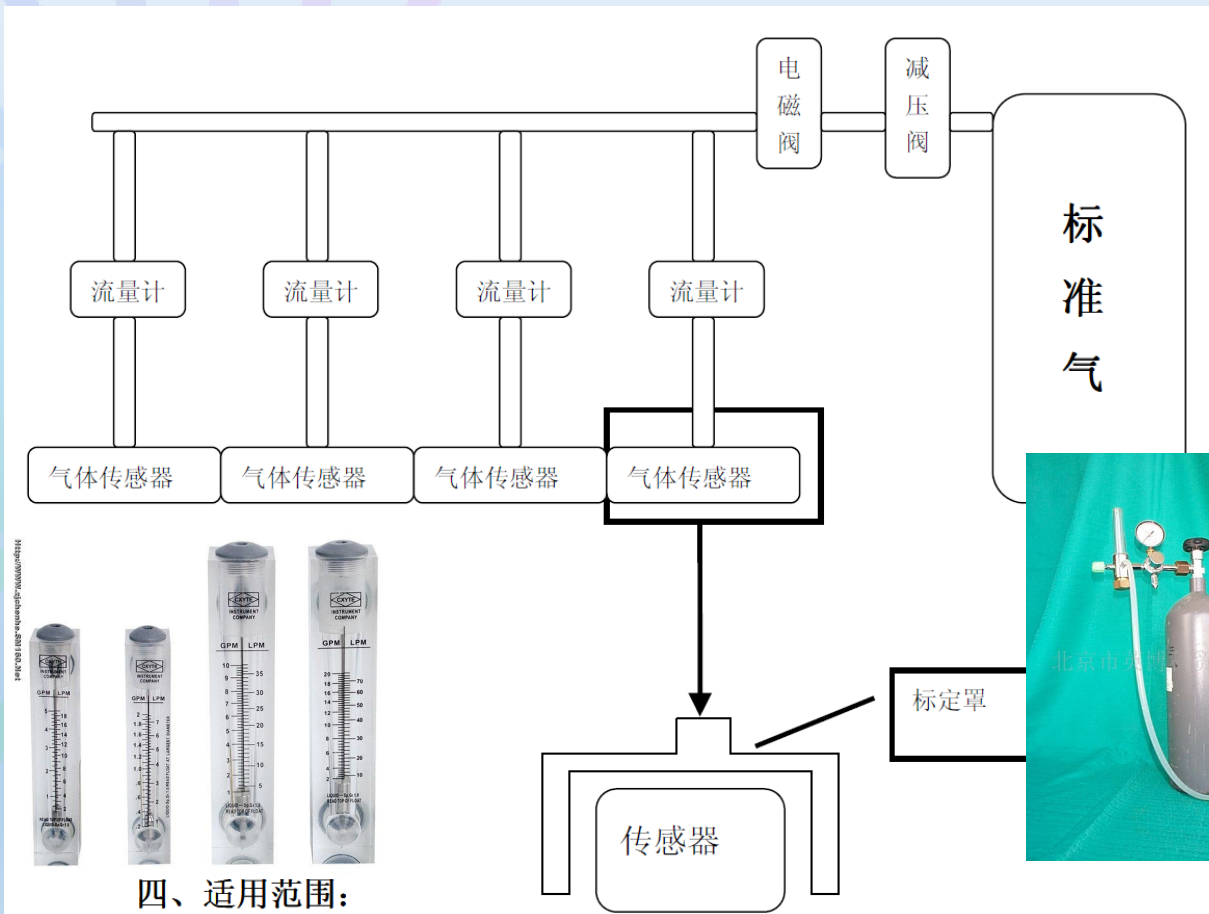



發展Arduino互動裝置的流程

- 規劃裝置所具有的功能和所需之軟/硬體
- 組裝硬體
- 編寫程式
- 驗證和編譯
- 上傳(燒錄)





參考資料

- 中央研究院原子與分子科學研究所暨國立中央大學物理系，強場物理與超快技術實驗室 暑期新生訓練講義。<http://hfp.phy.ncu.edu.tw/訓練/暑期新生訓練>
- 步進馬達：維基百科，.....
- 實作派電子實驗室<https://www.strongpilab.com/>
- Stanford Research Systems
<https://www.thinksrs.com/index.html>
- 太克台灣 <https://tw.tek.com/>
- 是德科技 <https://www.keysight.com/tw/zh/home.html>





參考資料

- LabVIEW:<https://labview360.com/default.asp>
- <http://sine.ni.com/nips/cds/view/p/lang/zht/nid/201793>
- 中央研究院IT's通訊
http://newsletter.ascc.sinica.edu.tw/news/read_news.php?nid=2782
- 維基百科<https://zh.wikipedia.org/zh-tw/Arduino>
- Arduino 官網 <https://www.arduino.cc/>
- Arduino 樂園 <http://arduino.tw/index.php>
- Cooper Maa 的 Arduino 筆記
<http://coopermaa2nd.blogspot.tw/search/label/Arduino>
- 超圖解Arduino互動設計入門(第2版), 趙英傑
- 台灣物聯科技<https://www.taiwaniot.com.tw/>

